



Work Safe for Life



Low-Slope Roofing

Health & Safety Manual



Low-Slope Roofing

Health & Safety Manual

Infrastructure Health & Safety Association
5110 Creebank Road, Suite 400
Mississauga, Ontario L4W 0A1 Canada
1-800-263-5024 ihsa.ca

IHSA has additional information on this and other topics.

Visit **ihsa.ca** or call Customer Service at **1-800-263-5024**

The contents of this publication are for general information only. This publication should not be regarded or relied upon as a definitive guide to government regulations or to safety practices and procedures. The contents of this publication were, to the best of our knowledge, current at the time of printing. However, no representations of any kind are made with regard to the accuracy, completeness, or sufficiency of the contents. The appropriate regulations and statutes should be consulted. Readers should not act on the information contained herein without seeking specific independent legal advice on their specific circumstance. The Infrastructure Health & Safety Association is pleased to answer individual requests for counselling and advice.

This manual was developed, reviewed, and endorsed by the Roofers Labour-Management Health and Safety Committee in association with IHSA.

The Infrastructure Health & Safety Association would like to thank working committee members for contributing their knowledge, experience, and time to produce a health and safety manual that will benefit both labour and management in the Low-Slope Roofing sector.

Special thanks to the Ontario Industrial Roofers Contractors Association and the Sheet Metal Workers International Association for their contributions to the creation of this manual.

© Infrastructure Health and Safety Association, 2013

All rights reserved. This publication may not be reproduced, in whole or in part, or stored in any material form, without the express written permission of the copyright owner.

Images supplied by the Health and Safety Executive contain public sector information published by the HSE and licensed under the Open Government Licence V1.0.

November 2013

ISBN 978-1-894761-19-2

Table of Contents

ACKNOWLEDGEMENTS

Chapter 1

RIGHTS AND RESPONSIBILITIES

- 1-1 Constructor's Responsibilities
- 1-1 Employer's Responsibilities
- 1-2 Supervisor's or Foreperson's Responsibilities
- 1-2 Worker's Responsibilities
- 1-2 Worker's Rights
- 1-3 Post on Site Checklist

Chapter 2

JOB SAFETY ANALYSIS

- 2-1 Creating a JSA
- 2-1 Changes to Work Conditions
- 2-2 Sample JSA for Setting Up an Extension Ladder
- 2-3 Job Safety Analysis Form

Chapter 3

EMERGENCY PREPAREDNESS

- 3-1 Emergency Response Plan and Procedures
- 3-2 Emergency Procedures for Fall Rescue
- 3-4 Emergency Response Planning Checklist

Chapter 4

OCCUPATIONAL HEALTH HAZARDS

- 4-1 Histoplasmosis
- 4-1 Legionella
- 4-2 West Nile Virus
- 4-2 Asphalt
- 4-3 Coal Tar Pitch
- 4-3 Lightweight Concrete

Chapter 5

HEAT STRESS

- 5-1 Heat Exhaustion
- 5-1 Heat Stroke
- 5-2 Precautions for Avoiding Heat Stress

Chapter 6

COLD STRESS

- 6-1 Frostbite
- 6-1 Hypothermia
- 6-1 Wind Chill
- 6-2 Preventing Cold Stress

Chapter 7

PLANNING AND HOUSEKEEPING

- 7-1 Planning
- 7-1 Public Way Protection
- 7-1 Setup
- 7-2 Access
- 7-2 Storage
- 7-2 Garbage Disposal

Chapter 8

PERSONAL PROTECTIVE EQUIPMENT

- 8-1 General
- 8-1 Head Protection
- 8-2 Foot Protection
- 8-2 Hand and Forearm Protection
- 8-3 Eye Protection
- 8-3 Hearing Protection
- 8-4 Protection from the Sun
- 8-4 Clothing

Chapter 9

FALL PROTECTION

- 9-1 Components
- 9-1 Safety Harnesses and Lanyards
- 9-2 Inspection
- 9-3 Travel Restraint
- 9-3 Fall-Arrest System
- 9-3 Anchor Systems
- 9-5 Temporary Guardrail Systems
- 9-5 Warning Barriers
- 9-6 Guardrails and Barriers

Table of Contents

Chapter 10

ROOF OPENINGS AND SKYLIGHTS

- 10-1 Roof Openings
- 10-1 Skylights

Chapter 11

ROOFING EQUIPMENT

- 11-2 Gas-Fuelled Engines
- 11-3 Vacuum Systems

Chapter 12

HOT-WORK HAZARDS

- 12-1 Torch-Applied Roofs
- 12-1 Hand-Held Torches
- 12-2 Welding Thermoplastic Membranes
- 12-3 Fire Watch and Plan

Chapter 13

LIVE SERVICES

- 13-1 Electrical Hazards
- 13-2 Lightning
- 13-3 Natural Gas Piping
- 13-3 Unknown Live Services
- 13-3 Solar Panels (Photovoltaics)

Chapter 14

ROOF ACCESS

- 14-1 Stairs or Elevators
- 14-1 Scaffold Stair Towers
- 14-1 Ladders

Chapter 15

MATERIAL LOADING

- 15-1 Hoisting and Rigging
- 15-1 Cranes
- 15-1 Elevators
- 15-1 Motorized Hoists
- 15-4 Gin Wheels (Hand Hoists)
- 15-4 Asphalt Pipes and Discharge Area
- 15-4 Conveyers

Chapter 16

KETTLES AND TANKERS

- 16-1 Kettle Start-Up
- 16-3 Loading of Kettles
- 16-3 Kettle Fires
- 16-3 Shutdown of Kettles
- 16-3 Rooftop Kettles
- 16-3 Emission Control Systems on Kettles (Smokeless Kettles)
- 16-4 Warming the Kettle
- 16-4 Tankers

Chapter 17

PROPANE, BURNERS, AND TORCHES

- 17-1 Training
- 17-1 General Propane Safety
- 17-1 Precautions with Propane Equipment
- 17-2 Precautions with Propane Burners
- 17-3 Precautions with Hand-Held Torches
- 17-3 Safety Checklist

Chapter 18

NIGHT ROOFING

- 18-1 Poor Visibility
- 18-1 Electrical Hazards
- 18-2 Alertness of Workers

Chapter 19

VEHICLE SAFETY AND TRANSPORTATION OF DANGEROUS GOODS

- 19-1 Vehicles
- 19-2 Trailers
- 19-2 Transportation of Dangerous Goods

Appendix:

MUSCULOSKELETAL DISORDERS

Musculoskeletal Hazards and Controls: Roofers

CHAPTER 1—Rights and Responsibilities

Each workplace party has certain responsibilities that contribute to a safe and healthy workplace. Before beginning work, it is important for everyone to know and understand their rights and responsibilities. This chapter discusses the various responsibilities and rights that are outlined in the *Occupational Health and Safety Act* and the *Regulations for Construction Projects* (O. Reg. 213/91). It also lists the documents that must be posted in an accessible location at all jobsites.

Constructor's Responsibilities

- Ensure that the project is supervised at all times.
- A project that lasts more than three months and has 20 or more workers, must have a Joint Health and Safety Committee (JHSC).
- If a JHSC is not required and there are more than five workers, the workers must choose a health and safety representative.
- Fill out a Ministry of Labour (MOL) Form 1000—Registration of Constructors and Employers Engaged in Construction.
- Keep a copy of all employer-approved forms (e.g., Form 1000) on site while employers are on the project.
- Send a Notice of Project form to the MOL if required. A Notice of Project form is required if the project is valued at more than \$50,000 or falls under one of the other conditions in section 6 of the construction regulations.
- Develop written emergency procedures, make sure your employees and subcontractors know what they are, and post them on site.
- Make sure there is ready access to a telephone, a two-way radio, or other communication system in case of an emergency
- Report every fatality or other prescribed incident, such as a critical injury, to the MOL.
- Make sure that all workers on site are at least 16 years old.

Employer's Responsibilities

Read sections 25 and 26 of the *Occupational Health and Safety Act*. They list many of the employer's responsibilities.

- Fill out a Ministry of Labour Form 1000—Registration of Constructors and Employers Engaged in Construction.
- If you have five or more workers, you must prepare and review annually a written Occupational Health and Safety Policy. You must also develop and maintain a program to implement the policy.
- Appoint a supervisor if five or more of your workers are on the project at the same time.
- Make sure that the workers on site are supervised at all times.
- Give workers the training that is required by law (on fall protection systems, WHMIS, etc.).
- If work must be done only by qualified workers, be sure the workers are qualified to do that work.
- Develop written procedures for rescuing a worker whose fall has been arrested (i.e., a worker hanging by a harness).

Note: The Regulations for Construction Projects (O.Reg. 213/91, s.26.1) requires that workers be protected from falls by a guardrail system. If it is not reasonably possible to install a guardrail system, the following can be used:

1. a travel restraint system
2. a fall restricting system
3. a fall arrest system.

Supervisor's or Foreperson's Responsibilities

- Make sure that workers use the methods, procedures, and equipment required by the *Occupational Health and Safety Act* and the *Regulations for Construction Projects*.
- Ensure that workers use or wear the equipment or clothing that the employer requires.
- Tell workers about actual or potential dangers.
- Give workers written instructions when required.
- Take every reasonable precaution to protect workers.

Worker's Responsibilities

- Choose worker representatives for the Joint Health and Safety Committee.
- Tell your supervisor or employer about equipment problems or other hazards that could hurt you or other workers.
- Follow your employer's instructions to use or wear equipment, protective devices, or specific clothing.
- Never engage in horseplay on site (pranks, competitions, showing off your strength, roughhousing, or unnecessary running).

Worker's Rights

Workers have the right to refuse work that they believe endangers their health or safety—or the health or safety of others. See section 43 of the *Occupational Health and Safety Act* for details about how to exercise this right.

Post on Site Checklist

Construction employers are required by law to have the following documents and information posted or available at each jobsite:

- Occupational Health and Safety Act and Regulations for Construction Projects* (the “green book”)
- Regulation 1101 (First Aid Requirements)

- Company health and safety policy and program
- Company workplace violence and harassment policy
- Ministry of Labour inspector's orders and report
- Material Safety Data Sheets (available)
- Emergency response plan
- Fall-arrest rescue procedures (available)
- In Case of Injury* poster issued by the Workplace Safety and Insurance Board (P085 available at ihsa.ca)
- MOL's Health & Safety at Work: Prevention Starts Here poster
- MOL's “Notice of Project” (Form O175) if the project is valued at more than \$50,000 or falls under one of the conditions in section 6 of the construction regulations.
- MOL Form 1000 “Registration of Constructors and Employers Engaged in Construction” (available)
- Name of constructor and head office info
- Address and phone number of the nearest MOL office
- DANGER signs in hazardous areas
- Location of toilets and clean-up facilities
- Valid certificate of first aider on duty
- Inspection card for first aid box
- Employer records of first aid treatment given (available)
- Name, trade, and employer of (as applicable):
 - o health and safety representative
 - o each member of the JHSC.
- Emergency phone numbers and location of nearest hospital (map)*

*Use IHSA's *Emergency Response Poster* (P103).

CHAPTER 2—Job Safety Analysis

Before the projects starts, make sure that your company's health and safety policy and program includes job safety analyses that reflect the jobs your workers will do.

A job safety analysis (JSA), also called a job hazard analysis or job task analysis, is a systematic analysis of work steps in a specific location that identifies the hazards and determines the controls.

By completing a JSA, you ensure that you have planned the work properly and that workers can do it safely. As a written document, it can serve as evidence of due diligence.

To be effective, the JSA must cover all aspects of a specific task. Most projects require several JSAs, and that isn't surprising when you consider the number of different tasks being done at the same time.

JSAs not only help prevent workers from getting injured, but they also help prevent damage to equipment and the environment. By doing this, JSAs help keep work on schedule.

Creating A JSA

The JSA should be written by a competent person because such a person, as defined by the *Occupational Health and Safety Act*, knows what the hazards are on the jobsite. Usually that person is the foreperson or supervisor.

If you are creating a JSA, this is the procedure to follow.

1. Write down the job steps

The first step is to identify the task, usually a situation that is repeated on many jobsites. For example, accessing a roof top or working near the roof edge.

Once you have a clear understanding of what the work involves, you need to break it down into manageable steps. These steps are not only specific to the job, but also specific to the work area. If the work area changes, the steps may need to change as well.

If the steps are too detailed, the JSA will be burdensome and difficult to follow. If they are not detailed enough, you may miss some hazards.

See sample JSA at the end of this section.

2. Identify the hazards associated with each step

This is the most challenging part of the JSA. Take each step and list the hazards associated with it. Think about what could go wrong from a health and safety point of view. Think about how people, equipment, materials, and the surrounding environment contribute to a hazard.

To help identify potential hazards, consider

- causes of past injuries
- other work going on near the work area
- legislation or regulatory requirements
- manufacturer's instructions for equipment.

3. Determine controls for each hazard

Each hazard you identified in the previous step needs a control. The control explains how you will eliminate the hazard or significantly reduce the risk of injury.

Use a chart like in the JSA form provided on page 2-3 to show the job steps, hazards, and controls. As reference, refer to page 2-2 for a sample JSA on setting up an extension ladder.

4. Discuss the JSA with your workers

Once you have completed the first three steps, you should have a well-developed JSA. Now, it's time to share it with your workers. The JSA won't be effective if workers don't know about it and understand it. The information on a JSA should be communicated to workers in a language they understand.

Before starting work, review the relevant JSA with your crew and make sure everyone knows how they are supposed to do the job. If you're dealing with a task that will last more than one day, it's a good idea to review the JSA each morning before work starts.

Changes To Work Conditions

We know how often work plans change. When things change, the supervisor or foreperson must update the JSA to include any new hazards, and then review the JSA again with all workers.

Keep in mind that if your workers do the same job in two different locations, you probably need two JSAs because the surrounding hazards may be different.

Sample JSA for setting up an extension ladder

Job Steps	Hazards	Barriers or Controls
<p>Lifting ladder off truck from braces</p>	<p>Strain and sprain</p>	<p>Use mechanical leverage to raise ladder from truck bracket, or mount in an easily accessible location.</p>
		<p>Lift one end at a time.</p>
		<p>Get assistance.</p>
		<p>Carry ladder with feet toward the front so it's ready to set up.</p>
<p>Carrying and setting up ladder</p>	<p>Strain and sprain</p>	<p>Lift ladder onto shoulder directly from truck bracket.</p>
		<p>Ensure good grip before walking.</p>
		<p>Get assistance from second worker for large ladders.</p>
		<p>Bend knees if setting ladder on ground.</p>
		<p>Set ladder feet on ground and walk towards wall raising ladder against wall. Practice this step with small ladders.</p>
	<p>Fall</p>	<p>Adjust ladder footing as required and, where applicable, secure bracing/ stabilizers in place</p>
		<p>Ensure ladder is not leaning, and is on firm footing, and secured from movement.</p>
	<p>Slip and trip</p>	<p>Ensure your path of travel is clear before removing ladder from truck bracket.</p>
		<p>Know where obstacles are before travelling with ladder.</p>
		<p>Make sure you have a clear set-down area.</p>
	<p>Electrocution</p>	<p>Check for overhead wires before setting up ladder.</p>
	<p>Next steps...Climbing, etc.</p>	

JSA No. _____

Job Safety Analysis Form

Company Name _____ Project _____

Contractor _____ Supervisor in Charge _____

Work Location _____ Estimated Start Date/Duration _____

Work Description _____

Trade Groups (including sub-contractors) _____

Major Equipment _____

Reference Material _____

Job Steps	Hazards	Barriers or Controls

Prepared By _____

Approved By _____ Date Approved _____

Instructions:

1. To be prepared by the supervisor most directly involved in the work.
2. Must be approved by preparer's management supervisor.
3. Must be reviewed by all workers involved in the work.
4. Emergency plan must be considered.
5. If the work plan changes and the JSA is amended, changes must be reviewed by all workers involved in the work.

CHAPTER 3—Emergency Preparedness

In order for everyone to be prepared for emergencies, every project needs an emergency response plan before work begins. This chapter explains what an emergency response plan is.

Emergency Response Plan and Procedures

An emergency is any situation that has the potential to harm the life, health, or safety of a person, public property, or the environment. It is an unplanned event.

The purpose of an emergency response plan is to ensure that emergency procedures are in place and every worker is prepared to respond to any emergency in a correct, timely, consistent, and dependable manner.

An effective plan must include the following:

1. Hazard Identification/Assessment

Identify hazards and assess potential risk by answering the questions: What can go wrong? What are the consequences?

2. Emergency Resources

Determine the resources available for the hazards identified and assessed. Verify that 911 operates in area. If not, make alternate arrangements. Maintain on-site resources such as fire extinguishers, spills containment equipment, and first aid kits. Outside help may be so far away that on-site resources are necessary, such as fire protection or ambulance/medical resources in remote areas.

3. Communication Systems

To relay accurate information quickly, reliable communications equipment must be used, procedures developed, and personnel trained. A backup system is a good idea in case the emergency destroys phone lines, for instance. The type and location of emergency communication systems must be posted on the project. Emergency phone numbers and the site address/location should be posted beside all site phones.

The *Emergency Response Poster* (P103), available from IHSA, can be used to record this and other information.

4. Administration of the Plan

The person in charge of administering and organizing the plan must ensure that

- everyone clearly understands their roles and responsibilities within the plan
- adequate emergency resources are kept in step with the progress of the project
- the plan is reviewed regularly and always after an emergency to correct any shortcomings.



5. Emergency Response Procedure

The Emergency Procedures chart (on page 3-2) outlines standard emergency response procedures. STOP and ASSESS the situation before performing any of the tasks. Stay calm to provide an example to others.

6. Communication of the Procedure

- Review with subcontractors, workers, and suppliers to ensure that it covers their activities.
- Review with owner/client in operating plants to ensure that hazards are identified and covered.
- Review with JHSC or health and safety rep on a regular basis to address new hazards or significant changes in site conditions.
- Post the procedure in a conspicuous location.

When developing your plan, make sure it always reflects current conditions on the jobsite. For more detailed information on developing emergency response plans, refer to the *Emergency Response Planning* (B030) booklet available from IHSA and the Emergency Response Planning Checklist at the end of this chapter.

Emergency Procedures	
1	 <p>TAKE COMMAND Assign the following duties to specific personnel.</p>
2	 <p>PROVIDE PROTECTION Protect the accident scene from continuing or further hazards—for instance, traffic, operating machinery, fire, or live wires.</p>
3	 <p>GIVE FIRST AID Give first aid to the injured as soon as possible.</p>
4	 <p>CALL AN AMBULANCE Call an ambulance and any other emergency service required. In some locales, dialing 911 puts you in touch with all emergency services.</p>
5	 <p>GUIDE THE AMBULANCE Meet and direct the ambulance to the accident scene.</p>
6	 <p>GET NAME OF THE HOSPITAL For follow-up, find out where the injured is being taken.</p>
7	 <p>ADVISE MANAGEMENT Inform senior management. They can contact relatives, notify authorities, and start procedures for reporting and investigating the accident.</p>
8	 <p>ISOLATE THE ACCIDENT SCENE Barricade, rope off, or post a guard at the scene to make sure that nothing is moved or changed until authorities have completed their investigation.</p>

Emergency Procedures for Fall Rescue

If a worker is involved in a fall arrest, it is important that the worker be brought to a safe place as quickly as possible without causing further injury or putting the rescuers at risk.

The construction regulations (O. Reg. 213/91, s.26.1(4)) requires that before workers use any fall-arrest system or safety net on a project, the employer must develop written rescue procedures.

In many cases, the rescue plan can be simple. A ladder or elevated work platform can be used to reach suspended workers and get them down safely. In other cases, it makes more sense to haul the worker back up to the level from which they fell or pull the worker in through a nearby window or other opening.

Sometimes the rescue may be more complicated. You may need specially trained and equipped rescue workers from the local fire department. Aerial ladder trucks or other high-reach equipment may be necessary. In extreme cases, the fire department may use rappelling techniques to reach trapped workers and lift or lower them to a safe place.

Create a rescue plan that is specific to your jobsite and that covers the different types of fall-related rescues that may be necessary. The plan should cover the on-site equipment that you will use, the personnel who will use it, and the procedures for different types of rescue. Any off-site rescue services that might be needed should be contacted in advance and arrangements made to familiarize them with the project.

Use IHSA's *Emergency Response Poster* (P103) to list the nearest hospital and the phone numbers of fire, ambulance, and police services.

Once the written plan is developed, you must ensure that

- everyone on site is aware of the rescue plan
- equipment and other resources you will need are available.

Take note: There are differences between equipment from different manufacturers as well as from different product lines in the same company. Therefore, the training must cover the same harness, lanyard, energy absorber, rope grab, lifeline, and anchorage that each worker will rely on, as well as the ways in which each will be used.

Sample Fall Rescue Procedures

Here are some examples of general fall rescue procedures to give you an idea of what your plan should include.

A. If an elevating work platform (EWP) is available on site:

1. Take it to where the suspended worker is.
2. Make sure that rescue workers using the EWP are protected against falling.
3. Be sure the EWP has the load capacity for both the rescuer(s) and the victim.
4. Use the EWP to reach the suspended worker.
5. Position the EWP platform below the worker.
6. Disconnect the suspended worker from his or her lanyard or lifeline when it is safe to do so. If the worker is unconscious or can't help with the rescue, two rescuers may be needed to handle the worker safely.
7. Treat the worker for suspension trauma and any other injuries.
8. Arrange to take the worker to the nearest hospital.

B. If an elevating work platform is not available:

1. Where possible, use a ladder (or ladders) to reach the suspended worker.
2. If the suspended worker is not in an area that rescuers can reach by ladders, move the suspended worker by his or her lifeline to an area that can be safely reached by ladder (if possible).
3. Rig a separate lifeline for each rescuer to use while carrying out the rescue.

4. Position the ladder(s) so that the rescuers can get beneath the suspended worker.
5. Securely attach a separate lowering line to the suspended worker's harness.
6. Rescuers on the ground lower the worker while the rescuers on the ladder(s) guide the worker. If the suspended worker is unconscious or can't help with his or her own rescue, two rescuers may be needed to handle the worker.
7. Once the worker has been taken to a safe location, administer first aid for suspension trauma and any other injuries.
8. Arrange to take the worker to the nearest hospital.

C. If the injured person is suspended near the work area and can be reached safely from the floor below or from the place from which the worker fell:

1. Make sure that all rescuers are protected against falling (such as by travel restraint or fall arrest).
2. If possible, attach a second line securely to the worker's harness to help pull him or her to a safe place. At least two strong workers will probably be needed to pull someone up.
3. Eliminate slack in the retrieving line to avoid slippage.
4. Once the worker has been taken to a safe place, administer first aid for suspension trauma and any other injuries.
5. Arrange to take the worker to the nearest hospital.

D. If a person has fallen and is suspended in an inaccessible place (e.g. on a tower, against a building, or in a structure that has no openings), you may need trained personnel and specialized rescue techniques to rescue the worker. For example, the rescuer may have to lower himself down to the suspended worker or use a lifeline to retrieve him or her.

Because of the inherent risk in this type of rescue, only people with specialized training should do it.

Emergency Response Planning Checklist

Company:	Date:
Completed by:	Site:

	In Progress	Date Completed
Program Administration (Who is responsible for implementing the plan?)	<input type="checkbox"/>	
Develop an Emergency Response Standard.	<input type="checkbox"/>	
Develop a Site Emergency Plan.	<input type="checkbox"/>	
• Identify emergency access routes.	<input type="checkbox"/>	
• Indicate location of first aid stations/boxes and fire extinguishers.	<input type="checkbox"/>	
• Show job office(s) and storage facilities (storage for blankets and special rescue equipment).	<input type="checkbox"/>	
• Ensure specialized PPE equipment is on site. (Indicate location.)	<input type="checkbox"/>	
• Ensure sufficient medical aid supplies are available on site (splints, stretchers, etc.) and indicate location.	<input type="checkbox"/>	
• Locate other firefighting equipment (standpipes, Siamese connections, and hydrants).	<input type="checkbox"/>	
• Locate main power supply to project.	<input type="checkbox"/>	
• Identify the location of emergency phones. (Post emergency list.)	<input type="checkbox"/>	
• Identify nearest hospital or medical centre.	<input type="checkbox"/>	
• Identify worker evacuation route(s) and assembly area(s).	<input type="checkbox"/>	
• Contact local fire, police, and ambulance and provide them with your site plan and list of potential emergencies.	<input type="checkbox"/>	
• Locate services to the project (both above ground and underground).	<input type="checkbox"/>	
• Develop on-site traffic routes.	<input type="checkbox"/>	

	In Progress	Date Completed
• Locate outside materials storage and fabricating areas.	<input type="checkbox"/>	
• Locate cranes, man/material hoists, and unloading docks.	<input type="checkbox"/>	
• Locate flammable/combustible materials and cylinder storage.	<input type="checkbox"/>	
• Locate garbage dumpsters and recycling bins.	<input type="checkbox"/>	
• Complete <i>Hazard Identification and Risk Assessment Form*</i> .	<input type="checkbox"/>	
• Identify if “high-level” rescue is a possibility.	<input type="checkbox"/>	
• Develop emergency response procedures for items identified in your hazard assessment.	<input type="checkbox"/>	
• Ensure that all trades on site keep daily personnel lists. (In the event of a major emergency, check names against personnel gathered in the assembly area.)	<input type="checkbox"/>	
• Include requirements for written notices. (What’s required? When? Completed by whom? Who does it go to?) See legal obligations.	<input type="checkbox"/>	
• Identify the emergency response (ER) team and alternates. (Post names.)	<input type="checkbox"/>	
• Provide specialized training for ER team members.	<input type="checkbox"/>	
• Designate a contact person to call necessary emergency services and MOL, MOEE, etc.	<input type="checkbox"/>	
• Select member of ER team to meet and direct emergency services vehicles to incident scene.	<input type="checkbox"/>	
• Select team member to deal with media, MOL, MOEE, etc.	<input type="checkbox"/>	
• Ensure all required rescue equipment/materials are readily available on site.	<input type="checkbox"/>	
• Provide for emergency traffic control person (properly trained).	<input type="checkbox"/>	
• Make provisions for cordoning off the accident scene to protect workers.	<input type="checkbox"/>	
• Ensure someone on the ER team documents where the injured worker has been taken (hospital, medical centre, etc.).	<input type="checkbox"/>	
• Set out method of communicating the plan.	<input type="checkbox"/>	

*Available at ihsa.ca/resources (Policy and Program Resources/Hazard Assessment)

CHAPTER 4—Occupational Health Hazards

Roofers are exposed to many chemical and physical hazards. Besides WHMIS-classified material, dangerous substances may come from many sources.

Occupational health hazards in roofing include cold weather in the winter, heat in the summer, and ultraviolet radiation from the sun.

This section describes some of the occupational health hazards encountered by roofers and ways in which they can be avoided or minimized.

Histoplasmosis

Histoplasmosis is a fungal disease that infects the lungs. It can be very serious if left untreated. The fungus grows in places where there are bat or bird droppings. When the fungus reproduces, it releases tiny bodies called spores. When the spores are disturbed, they become airborne and can be breathed into the lungs, where they may start an infection.

The disease cannot be transmitted from one infected person to another.

Health effects

The symptoms of infection range from non-existent to severe. If symptoms do appear, they generally start, on average, 10 days after exposure. Symptoms may include

- fever
- chest pains
- dry cough
- general feeling of being unwell
- infection of other parts of the body if not treated
- death if not treated.

Precautions

The following precautions can be taken to reduce a person's risk of exposure:

- Avoid places that may harbour the fungus (e.g., accumulations of bird or bat droppings).
- Before starting a job or activity that poses a risk of histoplasmosis infection, consult

the NIOSH/NCID information sheet called *Histoplasmosis: Protecting Workers at Risk*. This publication contains information on work practices and personal protective equipment that will reduce the risk of infection.

Legionella

Legionella is a dangerous bacterium that thrives in stagnant water, such as groundwater lakes, rivers, ponds and man-made water systems.

The main sources of exposure to contaminated water are

- cooling towers
- evaporative condensers
- water-spray humidifiers
- hot water storage tanks.

However, anything that creates mist should be considered a possible source.

Health effects

Breathing in the mist created by these systems can cause serious infection if legionella is present.

Legionella bacteria mainly cause two different diseases: Legionnaires' disease and Pontiac fever.

By far the more severe of those diseases is Legionnaires' disease. It usually develops two to ten days after exposure. The symptoms include

- cough
- fever
- chills
- diarrhea
- confusion
- pneumonia and organ failure in severe cases.

Pontiac fever is a mild flu-like illness that develops one to three days after exposure. Recovery usually takes place within two to five days without medical treatment. A healthy person exposed to legionella bacteria is far more likely to develop Pontiac fever than Legionnaires' disease.

Legionella bacteria are not transmitted from one person to another, and you do not get sick from drinking contaminated water.

Precautions

Take the following precautions when you are working in infected “hot zones” or near cooling towers, humidification systems, hot water tanks, or similar equipment:

- Find out if the water system is maintained in compliance with one of the two standards for controlling legionella (ASHRAE or CTI).
- Avoid stagnant water that has a film on it.
- Do not disturb stagnant water.
- Wash your hands with soap and water, or use an anti-bacterial hand sanitizer before eating, drinking, smoking, or leaving the worksite.
- Use personal protective equipment such as
 - leather gloves when handling equipment
 - rubberized gloves when using biocides or bleach
 - a NIOSH-approved N-100 full-facepiece respirator if there are suspected cases of Legionnaires’ disease or if the system could have significant contamination
 - a NIOSH-approved N-95 respirator if there is a possibility of exposure. Exposure is possible if the water system hasn’t been maintained, if there is stagnant water around that will be disturbed, or if indoor air-quality problems have been reported. (A NIOSH N-95 respirator is optional if the water system is maintained and there is no water or misting of water.)

West Nile Virus

West Nile virus is transmitted by the bite of an infected mosquito. For that reason, anyone who is outdoors is at risk of exposure.

Health effects

The symptoms of West Nile include

- headache
- high fever
- stiff neck
- disorientation
- tremors
- vomiting
- muscle weakness
- brain damage, which may be permanent or fatal in severe cases.

Precautions

- Reduce or eliminate mosquito breeding grounds (stagnant or standing water).
- Stay indoors when your work allows it.
- Wear long-sleeved shirts, long pants, and socks when possible.
- Use an insect repellent containing DEET or Picaridin on the skin and on the outside of thin clothing.
- Do not spray insect repellent on skin that is under your clothing.
- After working, use soap and water to wash the insect repellent off your skin and any clothing that has been treated with the repellent.
- Be extra cautious when mosquitoes are most plentiful—from early evening to early morning.

Asphalt

Asphalt is a complex mixture of chemicals derived from the petroleum refining process. When asphalt is heated, it releases vapours and fumes. These can be inhaled by roofers during hot asphalt applications. Asphalt fumes can also enter the body through the eyes or skin.

Health effects

The health effects of exposure to asphalt fumes include

- irritation of the eye
- irritation of the nose and throat
- coughing
- wheezing
- shortness of breath
- bronchitis
- skin irritation and rashes.

Precautions

- Prevent skin exposure by using disposable coveralls and leather-palmed gloves with cotton-backed knit wrists.
- Work upwind from the asphalt so that the fumes will blow away from you.
- Shower or wash up after work.
- Wash your hands before eating and smoking.
- Eat lunch in a clean place away from asphalt fumes.
- Refer to your MSDS for information about respiratory protection.

Coal Tar Pitch

Coal tar pitch is a black or brown, thick, sticky liquid that is extremely resistant to the elements. It was used extensively in flat and low-sloped roofing until the late 1970s. The removal of old coal tar roofing systems can produce dangerous dusts.

Health effects

Exposure can occur by contact with the skin or by inhalation. Skin contact with coal tar pitch and exposure to sunlight may cause an enhanced sunburn reaction called “phototoxicity.” Studies have shown that long-term exposure may also cause skin cancer.

Other studies show that inhaling dust from coal tar pitch may cause DNA damage. Coal tar pitch also has serious effects on the eyes.

Precautions

If possible, identify any unknown roofing materials before tear-off begins. Some old roofing felts may contain asbestos.

- Spray the part of the roof being removed with a fine mist, fog, or spray before removal.
- Work upwind so dust and fumes are blown away from you.
- Protect your eyes by using CSA/ANSI-approved safety glasses with side shields.
- Wear disposable coveralls to protect your skin. Use protective creams and sunscreen on exposed skin, such as the face.

- Wash up or shower after work.
- If clothes are contaminated, wash them separately from other laundry.
- Wash hands before eating, drinking, or smoking
- Use respiratory protection to protect against dust or fumes. For the right kind of respirator, consult the supplier or MSDS.

Lightweight Concrete

When lightweight concrete is being mixed and the bags containing the components are broken open, dust is created.

Health effects

The following health effects can be caused by some of the chemicals in lightweight concrete. However, the amount of a chemical in the concrete must be considered when evaluating the risk to health.

Inhalation

- Respiratory tract irritation from Portland cement may cause coughing, difficulty breathing, choking, etc.
- Allergic reaction in some workers who inhale hexavalent chromium can cause asthma-like symptoms such as wheezing and shortness of breath.
- Silicosis can result from repeated and prolonged exposure to silica.
- Some studies indicate a link between lung cancer and exposure to silica.

Skin Exposure

Some of the chemicals in lightweight concrete can harm the skin in various ways. However, when evaluating the risk to health, consider how much of a particular chemical is in the concrete.

Cement burns

Cement burns are caused by calcium oxide in Portland cement that becomes caustic when in contact with water or sweat on the skin. This can cause cement burns to exposed parts of the skin resulting in blisters, and dead and hardened skin that sometimes turns black or green.

Warning: Cement burns can be painless until you take off your boots or gloves at the end of the day.

Allergic contact dermatitis

Allergic contact dermatitis (ACD) can be caused by skin exposure to hexavalent chromium and nickel. Once you have become sensitized, even the smallest amount can lead to strong allergic reactions such as swelling and red, itchy rashes that become crusty.

Sensitization can occur after a single exposure, after repeated exposure over months or years, or never at all.

Irritant contact dermatitis

Irritant contact dermatitis (ICD) can be caused by contact with wet Portland cement. The caustic, abrasive, and drying properties of Portland cement can lead to cracked, dry, and broken skin.

Precautions for Protecting the Skin

- Wear alkali-resistant gloves.
- Wear long sleeves.
- Wear waterproof boots for standing in cement. If there is a risk of cement entering the boots, tape the boots to the pants.
- If kneeling on fresh concrete, use a dry board or waterproof kneepads.
- Remove jewellery such as rings and watches since cement can collect under them.
- If wet cement gets on your clothing, remove clothing right away and wash away the cement from your skin. Remember: Calcium oxide in cement can cause burns when in contact with water or sweat on the skin.
- Wash your hands, face, and exposed parts of your skin at the end of the job or before eating, drinking, smoking, or using the toilet.

Precautions for Preventing Inhalation

- For short-term use, an N95 filtering facepiece respirator may be enough. Usually, however, you need a minimum of a P100 half-facepiece elastomeric respirator.
- The mixing should be done in a place where the dust and fumes will be blown away from workers.
- When opening and pouring bags, avoid creating unnecessary dust.

Precautions for Protecting the Eyes

- Wear safety glasses with side shields when mixing or pouring.
- Under extremely dusty conditions, use unvented or indirectly vented goggles.
- Do not wear contact lenses.

CHAPTER 5—Heat Stress

The human body functions best within a surprisingly narrow range of temperatures: 36°C to 38°C (96.8° F to 100.4°F).

When you do heavy work in a hot environment—indoors or outdoors—your body heat rises. To get rid of this excess heat, your body uses two cooling mechanisms:

1. Your heart rate increases to move blood—and heat—away from your internal organs and toward your skin.
2. Sweating increases to help cool your skin, blood, and body through evaporation.

When you become dehydrated, your body's cooling system can't keep up with the heat, and your temperature rises above 38°C (100.4°F). This can lead to:

- heat rash (plugged sweat glands)
- heat cramps (due to loss of salt caused by sweating)
- heat exhaustion
- heat stroke.

Heat Exhaustion

Heat exhaustion occurs when your body cannot keep blood flowing both to vital organs and to the skin for cooling.

Symptoms

- weakness
- feeling faint
- headache
- breathlessness
- nausea or vomiting
- difficulty continuing work.

Treatment

Get medical aid and cool down (move to a shaded spot, loosen your clothing, and drink cool water). It takes at least 30 minutes to cool down the body after heat exhaustion. Without prompt treatment, heat exhaustion can lead to heat stroke.

Heat Stroke

Heat stroke is a medical emergency. You can die from it. Your body has used up all its water and salt and cannot cool itself. Your temperature rises to dangerous levels. Heat stroke is also called sunstroke.

Symptoms

- confusion and irrational behaviour
- convulsions
- loss of consciousness
- lack of sweating
- hot, dry skin
- abnormally high body temperature—40°C (104°F) or more.

Treatment

If a co-worker shows symptoms of heat stroke, you should act fast.

- Call the local emergency number or get the worker to a hospital.
- Take aggressive steps to cool the worker down by:
 - immersing in a tub of cool water
 - placing in a cool shower
 - spraying with a hose
 - wrapping in cool, wet sheets and fanning rapidly.
- If the worker is unconscious, don't give anything to drink.

Precautions for Avoiding Heat Stress

- Wear light, loose clothing that allows sweat to evaporate.
- Wear light-coloured clothing because it absorbs less heat from the sun.
- Drink one cup of cool water (8 ounces) every 20 minutes, even if you're not thirsty.
- Avoid alcohol and caffeinated drinks such as coffee, tea, or cola that make you urinate frequently.
- Avoid eating hot, heavy food. It can raise your body temperature by redirecting blood to your digestive system.

Remember that your physical condition can increase your risk of developing a heat-related illness. Age, weight, fitness level, health conditions (heart disease or high blood pressure), recent illnesses, previous heat-related illnesses, or medications can all reduce your ability to deal with the heat.

For more information on heat stress, refer to the *Construction Health and Safety Manual (M029)* or visit the **Heat Stress** topic page at ihsa.ca/topics_hazards

CHAPTER 6—Cold Stress

When you are cold, blood vessels in your skin, arms and legs constrict, decreasing the blood flow to your extremities. This helps your vital organs stay warm, but you risk frostbite in your extremities.

Frostbite

Having frostbite means that your flesh actually freezes. Blood vessels are damaged and the reduced blood flow can lead to gangrene. Frostbitten skin looks waxy and feels numb. Once tissue becomes hard, it's a medical emergency.

Treatment

- Get medical help.
- Warm the frozen area with body heat but do not rub it.
- Don't thaw hands and feet unless medical aid is distant and there's no chance of refreezing. The thawing is best done at a hospital.

Hypothermia

Hypothermia (also called exposure) is the condition of having an abnormally low core temperature.

Moderate Symptoms

- shivering
- blue lips and fingers
- slow breathing and heart rate
- disorientation and confusion
- poor coordination.

Severe Symptoms

- unconsciousness
- slowing heartbeat to the point where pulse is irregular or hard to find
- no shivering
- no detectable breathing
- resembles death—assume casualty is alive.

Treatment

- Hypothermia can kill—get medical aid immediately.
- Carefully remove casualty to shelter. (Sudden movement can upset the heart rhythm.)
- Keep the casualty awake.
- Remove wet clothing and wrap the casualty in warm covers.
- Apply direct body heat—warm the neck, chest, abdomen, and groin, but not the extremities.
- If conscious, give warm, sweet drinks.

Wind Chill

The wind makes your body lose heat faster. For example, when the air temperature is -30°C (-20°F), the following things can happen.

- with no wind there's little chance of skin freezing
- with 16 km/h wind (enough to fully extend a flag), your skin can freeze in about a minute
- with 32 km/h wind (enough to blow snow), your skin can freeze in 30 seconds.



Hard hat with balaclava

Preventing Cold Stress

- To capture air as an insulator, wear several layers of clothing rather than one thick layer.
- Wear synthetic fabrics next to the skin to “wick” away the sweat.
- If conditions require, wear a waterproof or wind-resistant outer layer.
- If your clothing gets wet at 2°C or less, change into dry clothes immediately and get checked for hypothermia.
- Wear warm gloves.
- Wear hats and hoods. You may need a balaclava.
- Do not wear tight boots or shoes—they restrict the blood flow. You should have enough room to wear either one thick or two thin pairs of socks.
- If you get hot while you’re working, open your jacket but keep your hat and gloves on.
- Take warm, high-calorie drinks and food.

For more information on cold stress, refer to the *Construction Health and Safety Manual (M029)* or download the safety talk on cold stress at ihsa.ca.

CHAPTER 7—Planning and Housekeeping

Many roofing injuries are related to materials handling and housekeeping. Roofers can reduce materials-handling injuries by limiting double handling and using devices that minimize manual labour.



Worker practicing good housekeeping

Housekeeping injuries can be reduced by ensuring proper clean-up and by keeping the job free of falling and tripping hazards. But housekeeping is not limited to picking up garbage. In roofing construction, housekeeping also includes proper planning, setup, access, storage, and garbage disposal.

Planning

Before or upon arriving on a jobsite:

- Decide on the set-up for access, storage space, and garbage disposal.
- Identify site hazards such as powerlines.
- Identify site limitations and restrictions, such as fire escapes or the need for the public to enter the building.

Note: Be sure to allow adequate time to set-up and clean-up.

- Consider safety issues such as public access, propane handling and storage, kettle location, fall protection, location and type of hoist required, and fire watch.
- Monitor the weather and adjust work schedule and assignments accordingly.
- Establish first aid and emergency procedures.

- Ensure clear communication between the estimator, project manager, supervisor, general contractor, and client.
- Provide PPE for all workers.
- Brief workers on site health and safety policy, hazards, and emergency procedures.

Working Alone

It is never recommended that a roofer work alone. However, if that is unavoidable, there must be a communication system between the roofer and someone who can help in an emergency.

Public Way Protection

You must take steps to protect the public in areas surrounding a construction site. If work is being done on a building or structure that is within 4.5 m (about 15 ft) of a public way (such as a sidewalk, road, etc.), that public way must be covered.

If work on a project may endanger the public, regardless of how far it is from any public way, a sturdy fence at least 1.8 m (about 6 ft) high must be built between the public way and the project.

For more information see “Public Way Protection”, sections 64–66 of the Regulations for Construction Projects.

Set-up

Considerations when setting up:

- protection of propane cylinders from traffic and sources of ignition
- firm ground for storage and hoisting purposes
- proper anchors or anchor points for lifelines and fall protection
- levelling of kettles, tankers, and propane tanks
- carrying capacity of the roof for storage and hoisting
- location of powerlines
- overhead obstructions to hoisting
- location of heating and cooling units on the roof

- condition of electrical cables for the heating and cooling units because of danger of electrocution if the units have to be moved

Note: When lockout and tagout is required or when a unit must be disconnected for relocation, the work must be done by a qualified electrician.

- vents and air intakes that can draw fumes into the building and vicinity
- securing of lids and spigots on kettles when work is finished for the day
- locking and securing of all trucks, hoists, box trailers, and equipment
- prevention of access to the roof by removing ladders and locking them up in a horizontal position at the end of the work day.

Access

- Allow proper movement for workers, material, and garbage. This includes the proper setup and maintenance of ladders. Ladder rungs and landing areas should be free of mud, ice and water. More than half of all ladder injuries happen at the top or bottom landing areas.
- Ensure proper setup of fall protection.
- In the winter, clear a path to the work areas.



Plywood makes it easier to move materials

Storage

- Store material properly, away from fire hazards.
- Secure materials to prevent them from rolling or falling accidentally from building edges and floor openings. Keep materials at least 2 m away from roof edges or openings. Rolls of

material such as asphalt felt should be banded to prevent accidental toppling and rolling.

- Secure material such as insulation and sheets of plywood to prevent them from blowing away in a strong wind .
- Keep storage area tidy, and store material in designated areas to reduce tripping hazards.
- When material must be stored on the roof, distribute it evenly. Make sure the weight in any one place does not exceed the roof capacity.

Garbage Disposal

- Dispose of garbage immediately to remove hazards underfoot.
- Pick up as you go to keep the ground or roof free of a buildup of garbage that may hide openings and other hazards.
- Do not allow garbage to fall freely from one level to another. It should be dropped down a chute or lowered in a container or by a crane or hoist.
- When using a chute, make sure that the bin below is covered to keep dust from flying around and that the chute is kept free of debris.

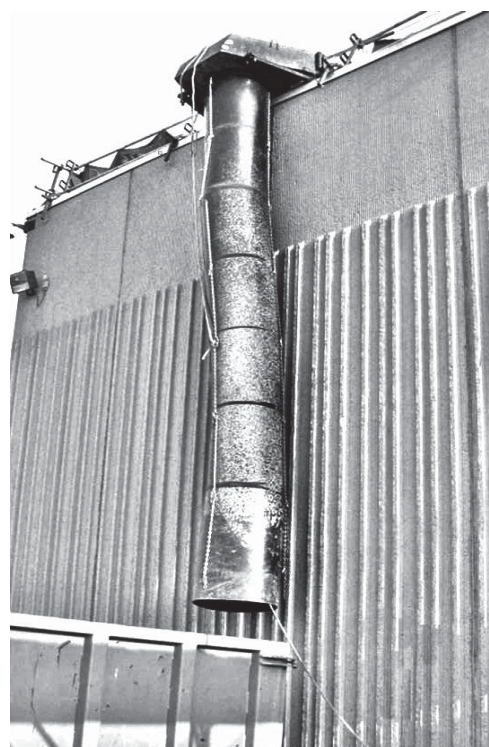

Garbage chute

- Designate an area for waste disposal.
- Avoid double handling.
- Remove full waste containers and replace them with empty ones.

Remember:

- Allow workers time to practise good housekeeping.
- Keep barricades and warning signs in place. If they are removed for roofing installation, loading, or unloading, replace them as soon as the task is finished.



Sample site layout for work, storage, and disposal

CHAPTER 8—Personal Protective Equipment

General

It is the roofer's responsibility to wear the protective equipment and clothing required by the *Occupational Health and Safety Act* and the Regulations for Construction Projects. In addition, roofers must wear any protective equipment required by the employer. This may include, but is not limited to, the clothing and equipment listed and shown below.

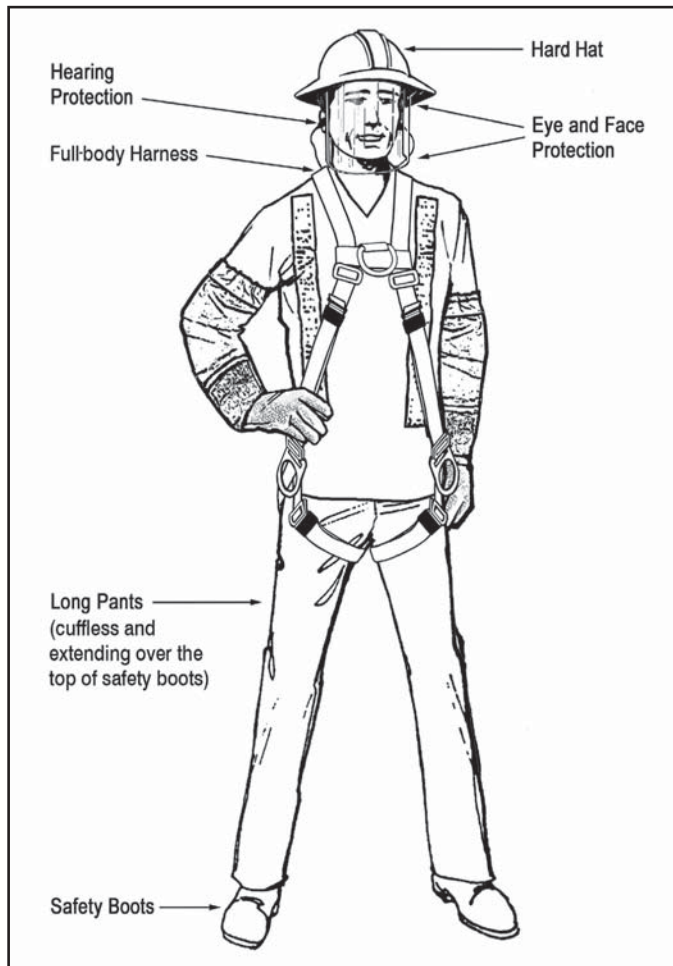

Personal protective equipment for roofers

Head Protection

The construction regulations requires that everyone on a construction site wear head protection.

The “Type” and “Class” of hard hat can be identified by the CSA or ANSI label. Some manufacturers also stamp the CSA or ANSI classification into the shell of the hard hat under the brim.

CSA

- Z94.1-05: Class E, Type 1
- Z94.1-05: Class E, Type 2
- Z94.1-1992: Class E

ANSI

- ANSI Z89.1-2009: Class E, Type I
- ANSI Z89.1-2009: Class E, Type II
- ANSI Z89.1-2003: Class E, Type I
- ANSI Z89.1-2003: Class E, Type II

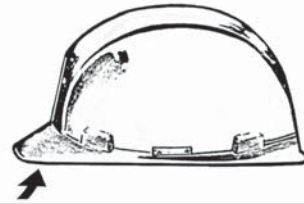

ANSI-Z89.1-2009, TYPE II, CLASS E



CSA Z94.1-05 CLASS E
TYPE 2

**CSA label stamped into the shell
indicating Class E hard hat**

Consider wearing a wide-brimmed hard hat because most of your work is done out of doors. The brim helps protect your face and neck from the sun's damaging ultraviolet (UV) rays.



Wide-brimmed hard hat

Foot Protection

When on site, roofers must wear CSA-certified Grade 1 footwear or CSA-certified footwear with heavy-duty toe and sole protection. Roofers should wear long pants that cover the top of the boots. In case of spillage, that prevents hot asphalt from getting into the boot and burning the feet.



Properly laced safety boot with CSA labels

There are also electrical hazards on site. On safety boots, a white label with the Greek letter omega in orange means that the boot offers protection against electric shock under dry conditions.



Greek omega label

Hand and Forearm Protection

Wear gloves when you are working with metal flashings, hot tar, or bitumen, or working on the kettle. Gloves that are weather-palmed and cotton-backed with a knit-wrist are best because they offer comfort and a good grip. Gloves should fit snugly at the wrist to keep out hot liquid.

There are new gloves specifically designed for roofers that protect the hands and forearms from burns. These gloves have cuffs that extend above the elbow and are kept in place with Velcro or elastic. If you do not have these gloves, use tape to bind the gloves more tightly to your wrist.

Chemical-Resistant Gloves

For protection against chemical hazards, the material safety data sheet (MSDS) for the

product being used should say whether gloves are needed and what they should be made of. MSDSs must be available on site for all controlled products being used.

Table 1: Glove Selection Chart

Chemical	Glove Selection
Acetone	Butyl Rubber
Cellosolve	PVA, PVC, Neoprene
Cellosolve Acetate	PVA, PVC
Cyclohexane	NBR, Viton®
Hexane	Neoprene, NBR, PVA
Methyl Alcohol	Neoprene, Rubber, NBR
Methyl Chloroform	PVA, Viton®
Methyl Chloride	PVA, Viton®
Methyl Ethyl Ketone	Butyl Rubber
Methyl Isobutyl Ketone	Butyl Rubber, PVA
Mineral Spirits	Neoprene
Naphtha	NBR, PVA
Perchloroethylene	NBR, PVA, Viton®
Stoddard Solvent	NBR, PVA, Rubber
Toluene	PVA, Viton®
Turpentine	PVA, NBR
Trichloroethylene	PVA, Viton®
1, 1, 1 Trichloroethane	PVA, Viton®
1, 1, 2 Trichloroethane	PVA, Viton®
Xylene	PVA, Viton®
PVA — Polyvinyl Alcohol PVC — Polyvinyl Chloride NBR — Nitrite Butyl Rubber Viton® — Dupont tradename product	

Table 1 specifies what kind of gloves to wear for protection against various chemicals that may injure the skin. This information can be used when the MSDS does not specify the type of glove to be worn.

For connecting or disconnecting propane, neoprene gloves are recommended.

Warning: Ordinary glove materials that are not rated as chemical-resistant do not protect against all hazards. Some solvents, degreasers, and other liquids can penetrate or dissolve rubber, neoprene, or PVC. Always use proper gloves (see Table 1).

Eye Protection

Wear properly fitted industrial-quality safety glasses on jobsites. Since roofers spend a great deal of time exposed to the sun, glasses with UV protection are strongly recommended.

When you are drilling into concrete or masonry or working near an operating roof cutter, wear goggles for protection against dust and flying particles.

Face shields, which protect against splashes, must be worn by roofers working with a kettle or tanker.

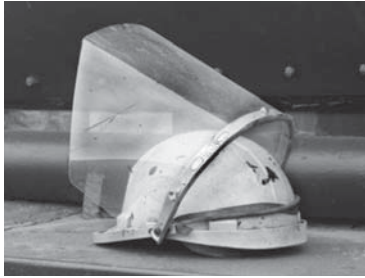

Kettleman’s hard hat with face shield

IHSA recommends that your safety glasses meet the requirements of CSA Standard Z94.3-2007 Class 1. Look for the manufacturer’s ID mark and the CSA logo on both the frame and the lens—they indicate industrial-quality glasses.

Hearing Protection

If you are working in noisy places or with noisy equipment, you should wear hearing protection. The noise from hoist motors, cutters, sweepers, torches, and other work on site can exceed 85 decibels. Noise at that level is harmful over prolonged periods.

Table 2 provides general guidance in selecting the right hearing protection for different noise levels.

Table 2: Recommended hearing protection

Level of Noise Exposure L_{EX} (dBA)	Grade	Class
< 90	1	C
< 95	2	B
< 100	3	A
< 105	4	A
< 110	Dual*	
> 110	Dual†	

* Dual hearing protection required. Use a minimum of a Grade 2 or Class B earmuff and a Grade 3 or Class A earplug.

† Dual hearing protection required. It is also recommended that exposure durations be limited, octave-band analysis be conducted for attenuation predictions, and twice-annual audiometry be provided to the affected individuals.

Note: These recommendations are based on a daily 8-hour exposure. Adapted from CSA Standard Z94.2-02

When choosing hearing protection, consider the following points:

- *Noise exposure:* Protect against the loudest noise possible with the equipment you operate or in the place where you work.
- *Comfort:* If the type you choose isn't comfortable, you won't wear it.
- *Appearance:* If you don't like how you look with the protection, you may not use it.
- *Communication:* Some hearing protectors actually make it easier to hear other people speaking in noisy places.
- *Safety:* You may feel isolated and unsafe if the protection is so high that you can't hear anything, including speech or warning sounds.

Foam Earplugs	Premoulded Earplugs	Earmuffs	Formable Earplugs	Custom-moulded Earplugs	Semi-insert Earplugs

Options for Hearing Protection

If hearing protection is not worn, limit the time you are exposed to high noise levels from equipment and tools. Refer to **Table 3** for maximum exposure times without hearing protection for common roofing equipment and tools.

Protection from the Sun

Ultraviolet (UV) rays are high-energy radiation, more powerful than visible light. There are two kinds of UV rays: UVA and UVB. These rays can cause sunburn, as well as mutations in your skin cell DNA which can lead to cancer.

We all see SPF on sunscreen bottles. It stands for sun protection factor. Here's how it works:

If you normally burn in 20 minutes, an SPF 30 sunscreen that is properly applied will protect you (under the same conditions) from burning for about 600 minutes ($20 \times 30 = 600$), which is 10 hours.

If you normally burn in 25 minutes, an SPF 15 sunscreen will protect you from burning for 375 minutes ($25 \times 15 = 375$), which is just over 6 hours.

When buying a sunscreen, always choose one with at least an SPF of 15. Choose a "broad-spectrum" sunscreen that will protect you from both UVA and UVB rays. If you are sweating heavily, reapply it often.

Don't forget about your ears, eyes, and lips. Use an SPF lip balm and wear safety sunglasses if the tint doesn't cause a safety hazard.

Clothing

On the job, do not wear:

- o loose or ragged clothing or cuffs
 - o greasy or oily clothing, gloves, or boots
 - o jewellery, especially rings and earrings
 - o sweatpants.
- Keep neck chains under your clothing so they do not hang out. If you have long hair, always keep it tied back.

- Clothing made of synthetic materials can be easily ignited and melted by hot asphalt or electrical flash. Cotton is more flame-retardant and therefore is recommended for work clothes.
- If your skin comes into contact with a dangerous or corrosive substance, wash immediately with water to avoid burns. Remove any contaminated clothing to prevent irritation.
- If your skin comes into contact with hot asphalt it's best to leave it alone and let the hospital staff look after it.
- Pant legs should not have cuffs. Cuffs trap dirt and liquid. Wear your pant legs over your boots, especially when you are carrying or working with hot asphalt. This will prevent spilled or splashed asphalt from getting into your boots and burning your feet.
- Roofers should wear long-sleeved shirts, buttoned at the cuffs. Kettlepersons should also wear protective over-sleeves.
- In the winter, your clothing should cover as much of your body as is practical.
 - o Wear a liner under your hard hat.
 - o Wear several layers of loose-fitting clothing so you can remove or add layers as the weather or workload changes.
 - o The insulation provided by clothing is directly related to the total thickness.
 - o Remove or open the outer layers during heavy work or during breaks so that the perspiration can evaporate.

Next to the skin

Synthetic fabrics such as polyester or polypropylene are not recommended for roofers since they burn very easily.

Middle layers

Thickness is the key. Stick to cotton and wool to prevent clothes from catching fire.

Outer layer

The best outer layers resist wind yet let moisture out. Tightly woven, thick wool, or cotton fabrics work best for roofers.

**Table 3: Noise levels and maximum exposure times
for common roofing equipment and tools**

Equipment	Operating conditions	Noise level (dBA)	Maximum exposure time without hearing protection
44-inch Sweeper - 5 HP motor	Machine running at operating speed	92	1 hr 35 min
	Idle	84	10 hr 5 min
Sweeper vertical shaft - 5 HP motor	Machine running at operating speed	89	3 hr 10 min
	Idle	84	10 hr 5 min
44-inch Sweeper - 11 HP motor	Machine running at operating speed	94	1 hr
	Idle	77	>10 hr
Single cutter horizontal shaft - 11 HP motor	Machine running at operating speed	94	1 hr
	Idle	78	>10 hr
Single cutter - 9 HP motor	Machine running at operating speed	97	30 min
	Idle	87	5 hr 2 min
Rotary planer - 8.5 HP motor	Machine running at operating speed	87	5 hr 2 min
	Idle	74	>10 hr
15-inch Rotary planer - 9 HP motor	Machine running at operating speed	98	24 min
	Idle	84	10 hr 5 min
Gravel spreader - 5 HP motor	Machine running at operating speed	94	1 hr
	Idle	78	>10 hr
1000-lb Track hoist - 8 HP motor	Machine running at operating speed	101	12 min
	Idle	89	3 hr 10 min
Diesel-generated trailer-mounted industrial vacuum - 6 feet away	Machine running-chute closed	96	38 min
	Machine running-chute open	100	15 min
Burners (2) on kettle	10 psi	85	8 min
	20 psi	104	6 min
Back-pack blower	Blowing snow	101	12 min
Quick-cut saw	Cutting 16-gauge sheet metal	108	2 min
Conveyor - 4 cycle	Machine running at operating speed	95	47 min
	Idle	87	5 hr 2 min

CHAPTER 9—Fall Protection

Components

Personal fall protection equipment is shown in the illustration below. This equipment can be used for fall arrest or travel restraint. Remember that workers must be trained in the use of fall protection and employers must have a rescue plan.

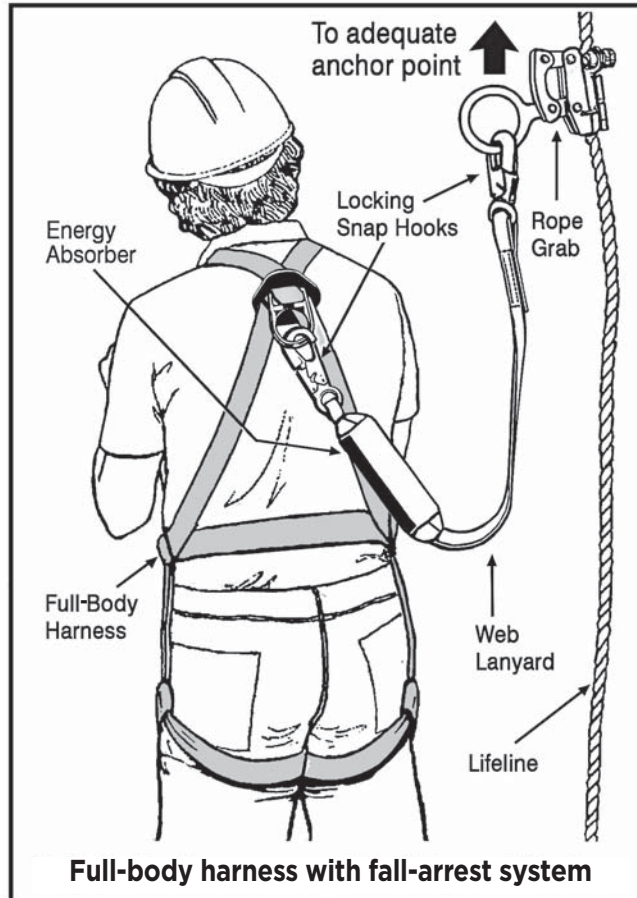

The following is a list of the current CSA Standards that pertain to fall protection equipment.

CAN/CSA-Z259.1-05 (R2010): Body Belts and Saddles for Work Positioning and Travel Restraint

CAN/CSA Z259.2.4-12 Fall Arresters and Vertical Rigid Rails

CAN/CSA Z259.2.5-12 Fall Arresters and Vertical Lifelines

CAN/CSA-Z259.2.2-98 (R2009): Self-Retracting Devices for Personal Fall-Arrest Systems.

CAN/CSA-Z259.2.3-12: Descent Control Devices

CAN/CSA-Z259.10-12: Full Body Harnesses.

CAN/CSA-Z259.11-05 (R2010): Energy Absorbers and Lanyards

CAN/CSA-Z259.12-11: Connecting Components for Personal Fall Arrest Systems (PFAS)

CAN/CSA-Z259.13-04 (R2009): Flexible Horizontal Lifeline Systems

CAN/CSA-Z259.14-12: Fall Restrict Equipment for Wood Pole Climbing

CAN/CSA-Z259.15-12: Anchorage Connectors

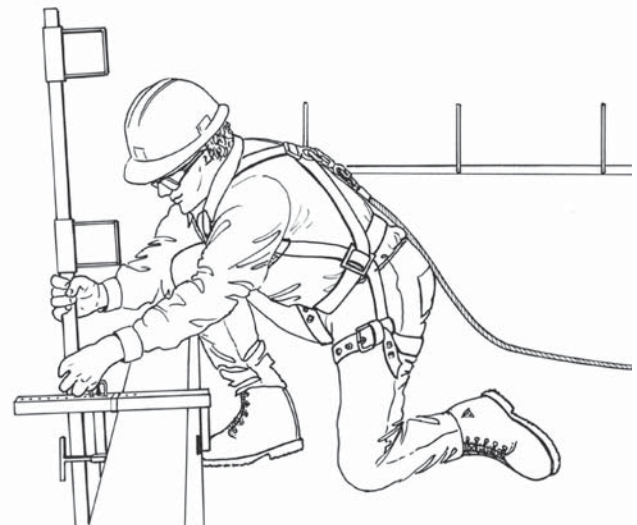

Worker wearing fall protection installing a guardrail

Note: Once any part of a fall protection system has been used to arrest a fall, it must be removed from service.

Full-Body Harness Fit

- Chest strap should be adjusted so that its snug and located near the middle of the chest. In a headfirst fall, a properly adjusted chest strap will prevent the worker from coming out of the harness.

- Leg straps should be adjusted so the users fist can fit snugly between strap and leg.
- Harness straps should be adjusted so that the D-ring is between the shoulder blades. A properly positioned D-ring will keep a worker upright after fall arrest.

Always refer to manufacturer's instructions for proper use and fit of a full-body harness.

Inspection

Always inspect every part of a fall-arrest system before each use. Consult the manufacturer's instructions for the inspection requirements of your equipment.

Harness

Make sure that

- the hardware and straps are intact and undamaged
- moving parts move freely through their full range of motion
- webbing is free of burns, cuts, loose or broken stitching, frayed material, and signs of heat or chemical damage
- the fall arrest indicator has not deployed.

Lanyard

- **Make sure the lanyard fastens securely to the D-ring on the harness.**
- Inspect the lanyard for fraying, kinking, and loose or broken stitching.
- Check the lanyard hardware for rust, cracks, and damage.
- Check energy-absorber regularly. Check the cover jacket for stress or tearing (many energy absorbers have a tag on the jacket that tears if the unit is exposed to a shock load—make sure this tag is intact).

Note: Energy absorbers come in two classifications: Class E4 is for workers weighing at least 45 kg (100 lb), but not more than 115 kg (254 lb); Class E6 is for workers weighing at least 90 kg (200 lb), but not more than 175 kg (386 lb).

- Be sure you are wearing the right lanyard for the situation. Different situations may require different lanyards. For example, a shorter lanyard may be needed to limit the fall distance.

- Most manufacturers do not permit two lanyards connected to the same D-ring. Consider using Y lanyards in place of two lanyards.

Lifeline

- Inspect the rope to see if it is in good condition. Consider the line unsafe, do not use it, and remove it from service if you find any of the following:
 - o tears, cuts, or burns
 - o strands that are different sizes or shapes
 - o discoloration
 - o broken or loose strands inside the rope (untwist the rope and check inside)
 - o an accumulation of powder or dirt inside the rope (untwist the rope and check inside)
 - o loose thimbles (make sure that thimble splices are in good condition).
- Make sure the rope grab is compatible with the type of rope you are using for your lifeline. Check the rope grab manufacturer's instructions.
- Make sure the lifeline is protected from rough or sharp edges.

Remember: It is always better to prevent the fall by limiting the distance you can travel so that you are kept away from the edge of the roof.

- Do not use Polypropylene rope as a lifeline.



Polypropylene utility rope

- Check self-retracting lifelines (SRLs) for smooth operation. Pull the line out and jerk it suddenly. The braking action should be immediate and tight. If it is being used in a horizontal position, check with the manufacturer to ensure that it is designed for that application.

Rope Grab

Check for:

- distortion
- rust
- moving parts that don't move easily
- sharp edges

When using a rope grab, also check for:

- the direction arrow and be sure it is pointing in the proper direction to prevent a fall
- make sure the rope grab is the right size for the type of rope.

Warning: If you fall, do not grab the rope grab. If you do, some grabs will not work properly and you risk being seriously injured or even killed.

Like all fall protection equipment, a rope grab that arrests a fall should be taken out of service and inspected before being re-certified for use.

Connecting Components

Check for:

- damage, cracking, dents, bends, or signs of deformation
- connecting rings centred—not bent to one side or otherwise deformed
- rust
- moving parts working smoothly
- signs of wear or metal fatigue.

Caution: It is not advisable to share your fall protection equipment with anyone else.

Remember to always check manufacturer's instructions for inspection of the specific fall protection equipment being used.

Travel Restraint

For roofing work, travel restraint rather than fall arrest is the recommended method of fall protection where there are no guardrails.

A travel-restraint system keeps you from getting too close to an unprotected edge. In other words, it restrains your travel.

The lifeline and lanyard are adjusted to let you travel only so far. When you get to the open edge of a floor or roof, the system holds you back.

Travel-restraint systems sometimes use a self-retracting lifeline. Note: when using an SRL as travel restraint, the length of the lifeline cannot extend past the edge of the roof. If it does, you are in a fall-arrest situation.

A full-body harness should be used with travel-restraint systems. You can attach the harness directly to the rope grab on the lifeline or by a lanyard. The lifeline must be securely anchored.

Fall-Arrest Systems

Where workers cannot be protected from falls by guardrails or travel restraint, they must be protected by a fall-arrest system.

In the event of a fall, a fall-arrest system must keep the worker from hitting the ground, the next level below, or any other objects below.

An arrested fall puts a tremendous amount of force on your body, and can sometimes cause serious injury. To minimize that force, always keep your fall distance as short as possible.

A fall-arrest system:

- must include a CSA-approved full-body harness
- must include a lanyard equipped with an energy absorber unless the energy absorber could cause a falling worker to hit the ground or an object or a level below the work
- must include an adequate fixed support and be connected to it by a lifeline or by a lanyard and a lifeline
- must prevent a falling worker from hitting the ground or any object or level below the work
- must not subject a falling worker to a peak fall-arrest force greater than 8 kilonewtons.

Anchor Systems

The lifeline of the fall-arrest system must be fastened to an adequate anchor or to the structure. The load exerted by a falling human body is considerable. The anchorage should be able to support the weight of a small car.

The lifeline should be kept reasonably taut without a lot of loose line between the worker and the anchor. SRLs remain taut automatically.

Remember to check with the manufacturer to ensure that it can be used in a horizontal application.

Choose the location of the lifeline anchorage to minimize the pendulum motion in the event of a fall arrest. This essentially means that the anchorage point should be directly behind the worker—preferably no more than 20 degrees off a line drawn straight back from the worker's position.

There are three main kinds of anchor systems for fall protection:

1. **Designed fixed support**—load-rated anchors specifically designed and permanently installed for fall protection as an integral part of the building or structure (e.g., roof anchors on high-rise buildings). Before using designed fixed supports, get assurances from the building owner that they have passed a recent inspection.
2. **Temporary fixed support**—anchor systems designed to be connected to the structure by a specific method (e.g., nail-on anchors used by shinglers)
3. **Existing structural features or equipment**—not intended as anchor points but verified by a professional engineer or competent person as being adequate to serve as anchor points (e.g., rooftop mechanical rooms, structural steel, or reinforced concrete columns).

A designed fixed support can be used to anchor a fall-arrest system, fall-restricting system, or travel-restraint system if the support has been installed according to the Building Code and is safe and practical to use.

Temporary fixed support can be used as anchorage if it meets the following three conditions:

1. It can support at least 8 kilonewtons (1,800 lb) without exceeding the allowable unit stress for each material used
2. When used with a fall-arrest system incorporating an energy absorber, it can support at least 6 kilonewtons (1,350 lb) without exceeding the allowable unit stress for each material used
3. When used with a travel-restraint system, it can support at least 2 kilonewtons (450 lb) without exceeding the allowable unit stress for each material used.

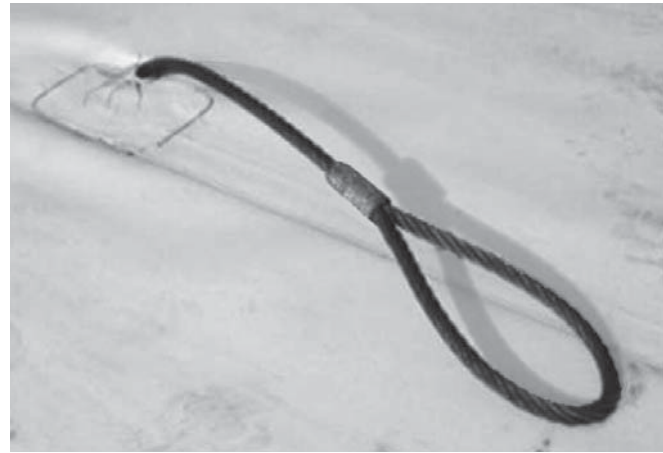

Temporary travel-restraint anchor fastened to an existing structural feature

In all cases, a **safety factor of at least two** should be applied when calculating the minimum load that an anchor point must support.

As a general rule with fall-arrest systems, choose an anchor capable of supporting the weight of a small car (about 3,600 lb).

When existing structural features or equipment are used as anchor points, avoid corners or edges that could cut, chafe, or abrade any part of the fall protection system.

Where necessary, use softeners such as wood blocking to protect connecting devices, lifelines, or lanyards from damage.

Never anchor to

- roof vents
- roof hatches
- small pipes and ducts
- metal chimneys
- TV antennas
- stair or balcony railings.

When no tie-off locations are available, other anchoring methods, such as approved mobile roof anchors, can be used. These devices are either placed on the roof or assembled on the roof as needed.

Always follow the manufacturer's instructions for setup and to find out the acceptable weather and roof conditions for using such devices.

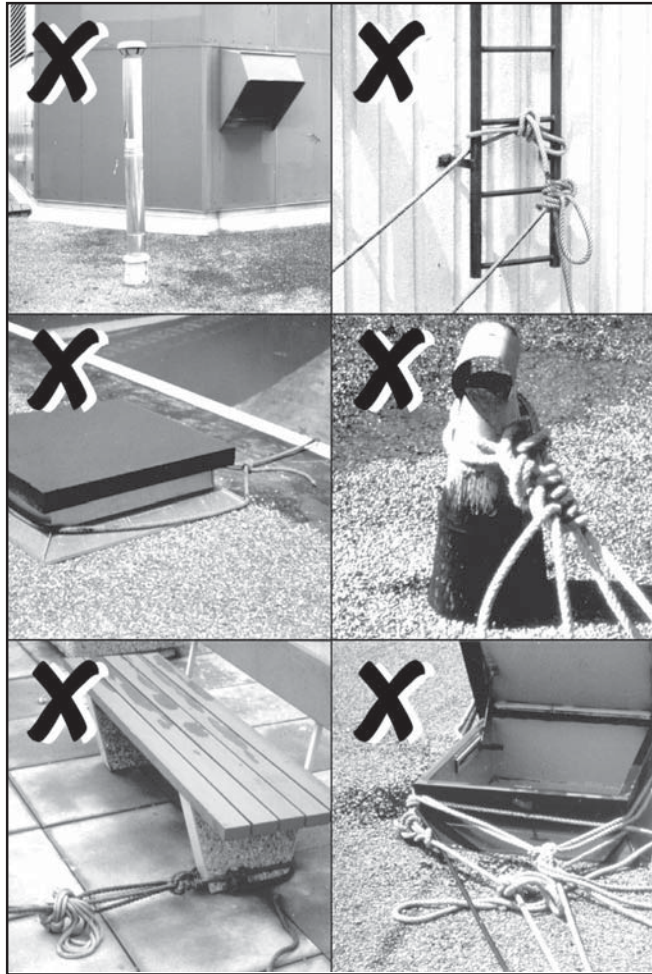

Examples of inadequate anchorage

Temporary Guardrail Systems

Guardrails are the preferred choice for fall protection. Any roof area not protected by guardrails should be separated with a warning barrier at least 2 m (6 ft 6 in) from the edge of the roof.



Guardrail system in place

Note: It is essential to secure guardrails according to the manufacturer's instructions so that the system will work properly.

Workers installing temporary guardrails should use a fall protection system whenever they are closer than 2 m (6 ft 6 in) to the roof edge.

Preferably, workers at the perimeter should use a travel-restraint system. If that is not possible, a fall-arrest system with the lanyard tied off to an adequately anchored lifeline must be used.

Portable guardrails may be used for short sections but are not suitable for long runs.

Note: There are many pre-engineered systems available. Be sure you understand all the manufacturer's instructions and follow them.

If there are two portable guardrails, they can be arranged so as to allow roofing from one edge to another.

Warning Barriers

Warning barriers used instead of temporary guardrails should be set up around the work area at least 2 m (6 ft 6 in) from the perimeter.

The work area is the area where roofing work is taking place within the warning barriers. If workers stay within this zone, no other means of fall protection is required.

According to section 207 (2) of the Construction Regulations, a warning barrier must be 1.1 m above the roof level and consist of portable weighted posts supporting a taut chain, cable, or rope. It should also have flags or warning signs.



Warning barrier with sign

Any work between the barrier and the roof edge requires a fall protection system, usually consisting of either a portable guardrail, a travel-restraint system, or a fall-arrest system.

The barrier should extend at least 3 m (10 ft) beyond the work area. Several work sections can be set up.

Guardrails and Barriers

Guardrails do not need to enclose the whole roof but only the section being worked on.

When only part of a roof is being worked on, the work area without the guardrail should be marked by a warning barrier.

For example, on single-ply roofing, the membrane can be folded back at 2 m (6 ft 6 in) from the roof edge, and a warning barrier set up to separate the work area from the space 2 m from the perimeter.

When work inside the warning barrier is finished, the barrier may be removed.

Workers must then use a fall protection system properly tied off and anchored when they are working on the portion of membrane 2 m or less from the roof edge. When work is done at

the edge of the roof, workers must always use a fall protection system unless they are protected by temporary guardrails, portable guardrails, or a parapet wall at least 90 cm (3 ft) high.

CHAPTER 10—Roof Openings and Skylights

Roof Openings

Guardrails must be installed around all roof openings that do not have permanent or temporary coverings.

When temporary covers are used, they should not extend any more than 15 cm (6 in) beyond the side of the openings they are covering. This will allow most of the roofing work to be done with the cover in place.

Coverings must also:

- cover the opening completely
- be fastened securely
- be adequately identified as covering an opening
- be made from material that can support all loads that may be placed on the covering
- be able to support a live load of at least 2.4 kilonewtons per square metre without exceeding the allowable unit stresses for the material used.

If there are permanent covers or hatch covers, they should be kept closed during roofing operations, except when the roofing crew is using the openings or when they are removed to complete the roofing work.

If openings are used for access to the roof, they should be surrounded with barriers.

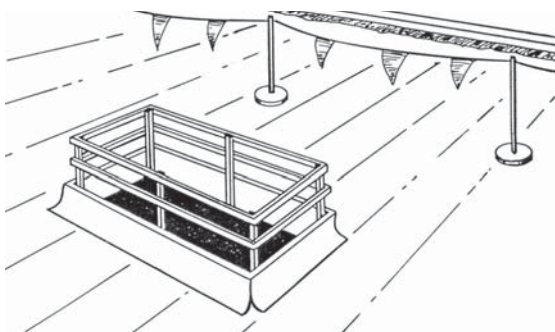

Roof opening protected by guardrail

If guardrails around openings or hatch covers must be removed to finish the roofing work, the workers doing the work should use a fall-arrest system. The work area should also be roped off and danger signs posted to warn other workers of the hazard.

Skylights

Before the skylights are installed, all skylight openings must be treated like other roof openings.

After a skylight is installed, it is often assumed that there is no more danger. However, a skylight itself has very little strength. If a worker stepped on it or fell onto it, it could break and the worker might fall to the level below.

To protect against that danger, install temporary guarding around or over each skylight in the vicinity of the work area. It is also a good idea to barricade the skylights on other parts of the roof to keep workers away from them.

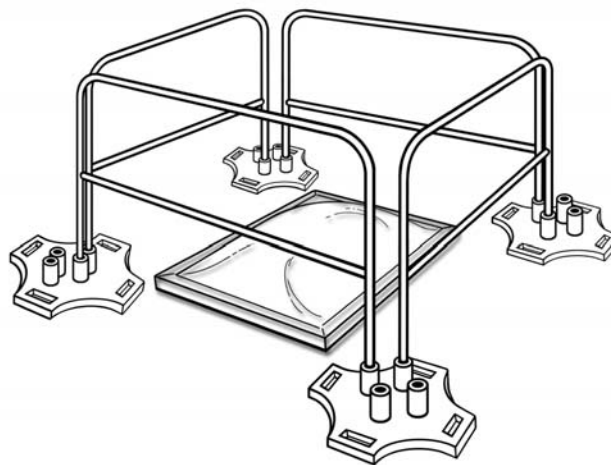

Guardrail and roof opening

CHAPTER 11—Roofing Equipment

Roofers are called on to use many different pieces of equipment. This section provides some general safety tips for working with equipment on roofs.

Employers are required by law to train all their workers in the proper use of the equipment they expect them to use.

If workers are not comfortable using a certain piece of equipment, they can tell their supervisor before doing any work with that equipment.

These are some common types of roofing equipment:

- roof cutters
- sweepers
- skid steers
- roof rippers
- material-handling carts.

The following are some useful safe practices when working with equipment on a roof:

- Know the roof capacity before hoisting powered equipment to the roof. Be sure the roof can handle the weight of the equipment and material.
- Always follow the manufacturer's instructions.



Cutter

- Be sure to operate and maintain all equipment according to the manufacturer's instructions. Use the recommended replacement parts only. An operator's manual should be available on the project.

- Do not modify any equipment unless the modifications are approved by the manufacturer.



Powered cart

- Use all PPE specified by the manufacturer and any additional protection required by your employer.
- Inspect the equipment before using it. Make sure the guards are in place, all controls are working properly, and all nuts and bolts are tight. Check structural welds. Look for cracks and metal fatigue.
- Make sure that no one is in front of the equipment before you start it.
- Shut off the engine when leaving the equipment unattended.
- Never try to override the deadman safety control.
- Inspect your work area before starting work. Look for
 - guardrails
 - bump lines
 - roof openings
 - other workers in the area who may be affected by your work
 - obstructions such as vents, hatches, drains, and skylights.
- Never walk backwards.
- Operate the equipment parallel to the roof edge, not at right angles to it. Use fall protection if it is required by the construction regulations or your employer.

- Stay away from the edge of the roof and roof openings.
- Always be aware of your surroundings.
- Do not start equipment when cutting heads or other components are bearing on the roof surface.
- When possible, reduce dust and fire hazards by wetting down the surface.



Planer

Gas-Fuelled Engines

Take the following precautions when operating gas engines:

- Check oil and other fluid levels regularly.
- Do not try to repair or adjust the machine when it is running.
- To refuel a gas engine:
 - Stop the engine.
 - Remove all ignition sources, including cigarettes, from the area.
 - Protect the roof from spills by laying material such as plywood under the equipment.
 - Use a funnel.
 - Have a fully charged fire extinguisher available.



Sweeper



Class "A" Extinguishers

For fires in **ordinary combustibles** such as wood, paper, and textiles, where a quenching, cooling effect is required.



Class "B" Extinguishers

For **flammable liquid and gas** fires, such as oil, gasoline, paint and grease, where oxygen exclusion or flame interruption is essential.



Class "C" Extinguishers

For fires involving **electrical** wiring and equipment where the non-conductivity of the extinguishing agent is crucial. This type of extinguisher should be present wherever functional testing and system energizing take place.

Fire Extinguisher

Vacuum Systems

Vacuums are used to vacuum the ballast off the roof and discharge it at ground level. When you are using vacuum systems, take these precautions:

- Keep the discharge area fenced off. The vacuum automatically discharges large quantities of ballast every few minutes.
- When using the vacuum nozzle, be aware of your surrounding and never walk backwards.
- Be sure to understand and follow all the manufacturer's instructions.



Vacuum



Vacuum discharge

CHAPTER 12—Hot-Work Hazards

Torch-Applied Roofs

Torch-applied operations can be dangerous for roofers and the public. The torch can reach temperatures over 1093°C (2000°F). Roofers may suffer serious burns from the torch or the hot modified asphalt they are applying. In addition, torching applications have been known to start fires that smoulder out of sight, only to burst into flame later, well after the torching is over.

When installing torch-applied roofs, take the following precautions:

- Wear the right personal protective equipment, including hard hats, safety boots, eye protection, and gloves. Clothing should be flame-resistant.
- Check the roof surface for combustible material. Remove what can be removed. Enclose the rest in hot- or cold-applied membranes, sealing off all intakes and projections to prevent flame from spreading into combustible material.
- Inspect equipment and torches before using them. They must be in good working order, with fittings, hoses, and head secure and cylinder valves clean.
- Don't use leaking propane equipment. If a leak occurs during operation, stop immediately.
- Store equipment in protective cases.
- When a torch is not in use, set it in its support-leg position with the torch head pointing at an upward angle. Don't rest it on a curb or roof edge.
- Unless you are the torch operator, stay at least 2 or 3 m away from the flame.
- Do not torch directly on cant strips, insulation, wood, grease, lint exhaust, or any other flammable material. Never torch directly at flashing, corners, voids in the roof or roof deck, or behind metal counter-flashings.
- Take extra care when torching near pipes, fresh air vents, and HVAC units because the flame could be sucked into the building.
- Do not torch near gas and electrical lines.
- When shutting off the torch, close the valve of the propane cylinder first. Let the remaining gas in the hose burn off, and then close the torch valve.
- Disconnect the hose at the end of the day.
- Have at least one fully charged 20-lb dry-chemical fire extinguisher within 6 m (20 ft) of each worker using a torch.
- Perform a fire watch every day.
- Never leave lit torch unattended.

The employers must make sure the workers have been trained to install torch-applied modified-asphalt roofing systems. Their training should include the storage, handling, and use of roofing propane.

Hand-Held Torches

Hand-held torches fuelled by 9.1-kg (20-lb) propane cylinders are used for many operations in the roofing industry, such as melting snow and ice, drying roof decks, and heat sealing.



Worker using hand-held torch

- Never leave torches ignited and unattended.
- Never use hand torches inside a building.
- Make sure the propane cylinder is properly secured and in an upright position.
- Use only approved high-pressure hoses to connect torches to regulators.

**Torch**

- When an operation is finished, always shut off the container valve first. Allow the gas in the system to burn off. After the flame has gone out, shut off the torch control.
- Operate the torch at the manufacturer's recommended pressure.
- Never direct the flame at, near, or toward the cylinder.

Welding Thermoplastic Roof Membranes

Both automatic and manual systems are used in the roofing industry to weld thermoplastic roof membranes. These systems use electricity to heat air, which in turn welds the membrane together. Air temperatures may reach 600°C (1100°F). Some automatic systems require up to 220 volts. Burns and electrocution are obvious hazards with this equipment.

**Roof membrane hot-air welder**

Workers assigned to operate welding equipment must be trained and certified by the manufacturer of the thermoplastic roof system.

The equipment must be maintained according to the manufacturer's instructions.

Safe Practices

Electrical

- Don't use thermoplastic hot-air welding equipment in the rain or where surfaces may be wet.
- Make sure the equipment is protected from the weather overnight or when not in use.
- Inspect electrical cables regularly for damage.
- Always use ground fault circuit interrupters (GFCIs) when using welders. By law, GFCIs must be used with any portable electrical equipment operated outdoors.
- Do not touch grounded objects such as pipes or scaffolding while operating thermoplastic hot-air welding equipment.

Fire

- Do not use the equipment near flammable gases or liquids.
- Do not let the equipment remain stationary with the heat on and the welding nozzle close to any surface.

Fumes

- Fumes from thermoplastic welding may irritate the nose and throat. Stay out of the smoke plume, and keep upwind whenever possible. Wearing respiratory protection such as a half-mask N95 respirator will reduce your exposure to the fumes.
- Do not overheat thermoplastic membranes. At normal welding temperatures, very few harmful chemicals are released. But when the thermoplastic is overheated, compounds such as hydrogen chloride and vinyl chloride monomer may be produced.

Steep slopes

- Do not use automatic welding machines on slopes greater than 20 degrees when welding at right angles or greater than 25 degrees when welding in the direction of the slope. Steeper slopes may cause the machine to tip over, stall, or move too fast.

Fire Watch and Plan

The roofing contractor's health and safety policy should provide for an emergency plan and a fire watch after torching applications.

Fire Plan

A fire emergency plan might include instructions like the following:

- Designate a person to be responsible in the event of an emergency.
- Make sure all workers know the escape route.
- Be prepared to call 911 if there is an emergency.
- Have at least one fully charged 20-lb dry chemical fire extinguisher available.

Fire Watch

Stop torching at least two hours before leaving for the day.

At the end of the workday, use an infrared thermometer to inspect the roof for hot spots. Keep a log of all temperature readings.

At the end of the monitoring period, inspect the building interior (with the owner's representative) before leaving the site.

CHAPTER 13—Live Services

For more information about electrical safety, refer to IHSA's M029 *Construction Health and Safety Manual*.

Electrical Hazards

Live Services Embedded in Roof Decking

Cutting into an existing roof for penetrations is a common job for roofers. There is a possibility that electrical services such as conduits or cable could be just beneath the membrane of a roof. Electrical services may also be connected to the underside of the roof deck on the inside of the building and could pose a hazard as well. The following steps may help to prevent an unexpected electrical contact:

- Before cutting into the roof, ask the owner for information on the location of conduits or cable.
- If possible, check the underside of the roof deck inside the building for conduits and cable in the location where the cutting will take place.
- If the roof deck is concrete, have the area scanned or x-rayed before you cut into it.
- Always remove the membrane system before cutting openings in the roof deck.
- If there is an electrical service close to the future hole, ask to have the power shut off and locked out.
- If the power cannot be shut off and locked out, ask for a new location to be chosen for the hole.

Contact with electricity can cause serious burns or even kill you. Do not cut until you have received confirmation that the area is clear of all services.

Be aware that the same hazards exist when you are fastening roof membrane mechanically to the decking. If possible, check the underside of the roof deck inside the building for services. Two-way communication between someone watching from inside the building and someone on the roof may be necessary.

Radio detection is also becoming a reliable way to check for electrical services close to the roof. Before fastening the roof membrane to the decking, a worker scans the area with a radio detection device and marks areas of concern. This method can lower the risk of contact.

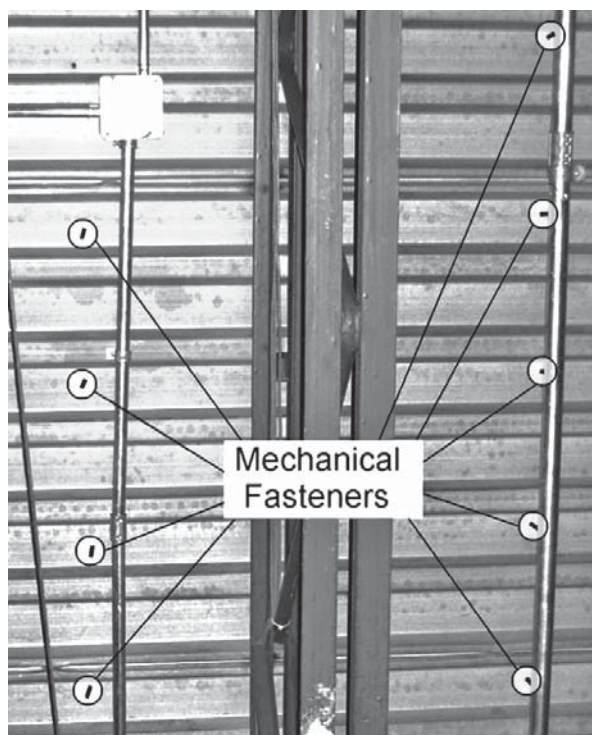

Mechanical fasteners near electrical services

Note: If electrical services are found and there is a risk of touching them, investigate alternatives to fastening the decking mechanically.

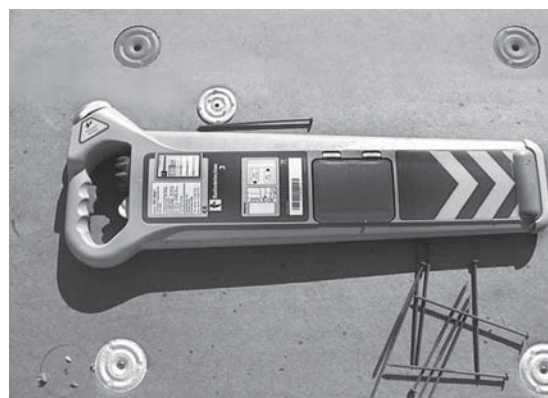

Scanner for electrical services

Powerlines

In many cases, the power feed to a building is on the roof. Powerlines can be deadly if you touch them. The table in section 188 of the construction regulations lays out the safe working distances from powerlines. They are as follows:

Minimum distances by voltage

Voltage Rating of Powerline	Minimum Distance
750 to 150,000 volts	3 metres (10 ft)
> 150,000 to 250,000 volts	4.5 metres (15 ft)
> 250,000 volts	6 metres (20 ft)

Here are a few tips for preventing accidental contact with powerlines:

- Before starting work, find the powerline into the building and assess the danger.
- If the powerline is a hazard, ask to have it de-energized. If that is not possible, protective insulation should be placed on the line. To arrange for that, contact the local power authority.
- When working near overhead powerlines, use ladders made of a non-conductive material (fiberglass or wood).

Note: Powerline covers do not prevent shocks.



Powerline with protective insulation

Generators

- Operate generators outside only, because they produce large amounts of carbon monoxide (CO).
- Keep them away from workers to reduce their exposure to noise.
- Don't leave extension cords attached to the generator when it is not being used—cords are a tripping hazard.

- Use an outdoor type 300V or 600V cord.
- To prevent damage to tools and cords, use heavy-gauge wire (12 AWG is ideal) for long runs or big tools.
- Protect cords from hazards like hot asphalt, water, and sharp edges.
- Roll up cords after you have finished with them.
- Use a cart or dolly to move large or heavy generators or get someone to help you.
- Follow the manufacturer's instructions for proper grounding. Use only generators labelled "NEUTRAL BONDED TO FRAME."
- Always use ground fault circuit interrupters (GFCIs). Install the GFCI close to the generator (if it is not built into the generator). Test the GFCI after you have grounded it.
- Store fuel away from sources of ignition, and give the engine time to cool down before refuelling.
- Have a 4A:40BC-rated fire extinguisher ready and know how to use it.

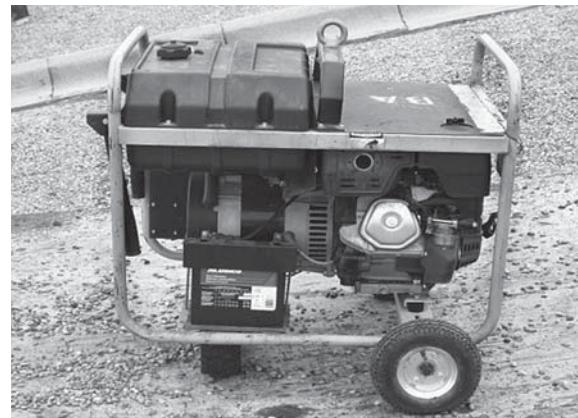

Portable generator

Lightning

Roofers have been seriously injured and killed by lightning. Here are some ways of protecting yourself against this hazard.



- If you are on a roof or ladder and you hear a storm coming, get down to the ground.
- Count the length of time between seeing the lightning and hearing the thunder. Every second represents about 300 m. So 6 seconds means the lightning is about 2 km away. However, lightning can reach you even if the storm is 16 km away and there's a clear sky above you.

- Use the 30-30 rule: take shelter when the lightning is 30 seconds away or closer. Stay inside until 30 minutes have passed since you last heard thunder or saw lightning.
- When you are inside, stay away from windows or doors and do not touch electrical equipment, metal walls, or other conductors.
- If you are in the open during a thunderstorm and you can't get inside, stay away from trees, hills, and water. Make yourself as small a target as possible, but never lie down on the ground. Instead, crouch down in a baseball catcher's stance, put your hands on your knees, and duck your head.

Natural Gas Piping

Natural gas piping is found on many roofs. They are used primarily to feed roof-top air-handling units. The following are some precautions to take when working around natural gas piping.

- Gas lines should be inspected before roofing work begins.
- If gas lines appear to be in poor condition, have them checked for leaks.
- When gas lines interfere with roofing work, have them disconnected.
- Be careful when installing ramps over gas lines. Most roofing operations require hot work, and if a gas line leaks or breaks, there could be an explosion.
- Be cautious when working around live rooftop units such as HVAC.
- Avoid torching around natural gas pipes.
- Make sure gas pipes are supported properly during roofing work.
- If a gas pipe is disturbed, the connections at the rooftop unit could be damaged. They should be tested for leaks.

Unknown Live Services

If unknown electrical service lines are found on a rooftop, they should be considered live and dangerous. If the unknown service line affects the work, ask the owner to have the service disconnected while the work is being done. If that is not possible, follow the precautions described in the following sections.

Solar Panels (Photovoltaics)

Solar panels, also known as photovoltaics or PVs, are installed on racks and are mounted on roof-penetrating support stands or installed on curbs or sleepers. The most popular method of mounting these systems on existing buildings is to ballast the racks. PV cells are grouped into modules that collect and convert solar radiation into direct current (DC) electricity. A group of PV modules mounted on a support structure or rack is referred to as a PV array. Some PV systems are called "building-integrated photovoltaics" (BIPV) because the PV modules are attached directly to the roof surface.

How Do They Work?

Inverters built into these systems convert the DC current to alternating current (AC). These rooftop assemblies are most commonly rated at 250 kilowatts (kW). However, they may exceed 500 kW with greater than 600 volts. And here is the danger for the roofing worker—because rooftop PV modules are live with DC current.



Ballasted PV system

Effect on Roofers

Roofing contractors normally employ both service and maintenance crews. Service crews are often sent to a customer's building to repair roof leaks or other failures in the roofing system. Rooftop maintenance, on the other hand, is generally preventive work where crews make non-emergency alterations to the roofing system.

When access to the roofing membrane and flashings is restricted, it is difficult for the roofer to make the necessary repairs.

More and more, roofs are being used for purposes other than weather protection. Roofing membranes are often buried or unreachable. The increasing number of rooftop PV systems is adding to this problem.

Regardless of whether the PVs are integrated or ballasted, they make it harder for roofers to work on the membrane system. The ballasted procedure is a particular problem because the ballast support pads sit directly on the roof.

Safe Work Practices

Rooftop PV panels are live with DC current. As long as they are exposed to light, they cannot be switched off. Before the roofers go onto the roof, they must be warned that the panels are there. They must not enter these areas without a representative of the owner, and that person must understand how the PV system works and where the essential components are.

An array of conductors connected to PV modules that are exposed to light remain energized even after they have been disconnected at the junction boxes, combiner boxes, and inverters.

Roofers must guard against accidentally touching any exposed part of a PV array conductor. They should inform the building owner of any electrical dangers they encounter and refuse to do the work until the roof area in question has been made safe.

Many PV systems are designed to provide maximum coverage over the building's rooftop. It is not unusual to find the panels and racks installed right up to the edge of the roof. These types of installations make it particularly difficult for roofers to follow the usual fall protection procedures. Before doing any roofing work on these buildings, make sure that a hazard assessment is done to determine how best to employ fall protection and other safety procedures.

It is a good idea for companies to revise their safety programs and policies to include procedures for working around rooftop PV installations. Those programs should include additional training for workers who may be exposed to PV systems.

Note: Ponding or standing water around PV systems creates a hazardous work situation. Keep that in mind when planning your work.

CHAPTER 14—Roof Access

Stairs or Elevators

Whenever possible, roofers should use existing stairs or elevators for access to the roof.

Scaffold Stair Towers

Safe access to the roof is of the utmost importance; that is why it is becoming more and more common in the roofing industry to use scaffold stair towers for roof access.

Scaffold stair towers provide the following benefits:

- They specify where workers can get onto the roof and can be positioned to provide access at the safest place.



Stair tower

- They have none of the risks associated with ladders.
- It is safe and convenient to carry things while climbing to and from the roof.

Remember, the erection of a scaffold stair tower must be supervised by a competent worker, and done in accordance with the manufacturer's instructions and the construction regulations.

Ladders

If there is no other means of access, such as stairs or a scaffold stair tower, ladders may be used. Ask for help when installing access ladders.

Ladders must

- be in good condition
- comply with Sections 78–84 of the Regulations for Construction Projects (213/91)
- be tied off or secured to the structure at both the top and bottom
- be set up so that a slope of at least 3-to-1 and not more than 4-to-1 (vertical to horizontal) is maintained for sloped ladders
- extend at least 90 cm (3 ft.) above the roof access level
- be no longer than 20 m (66 ft) in the case of sloped ladders

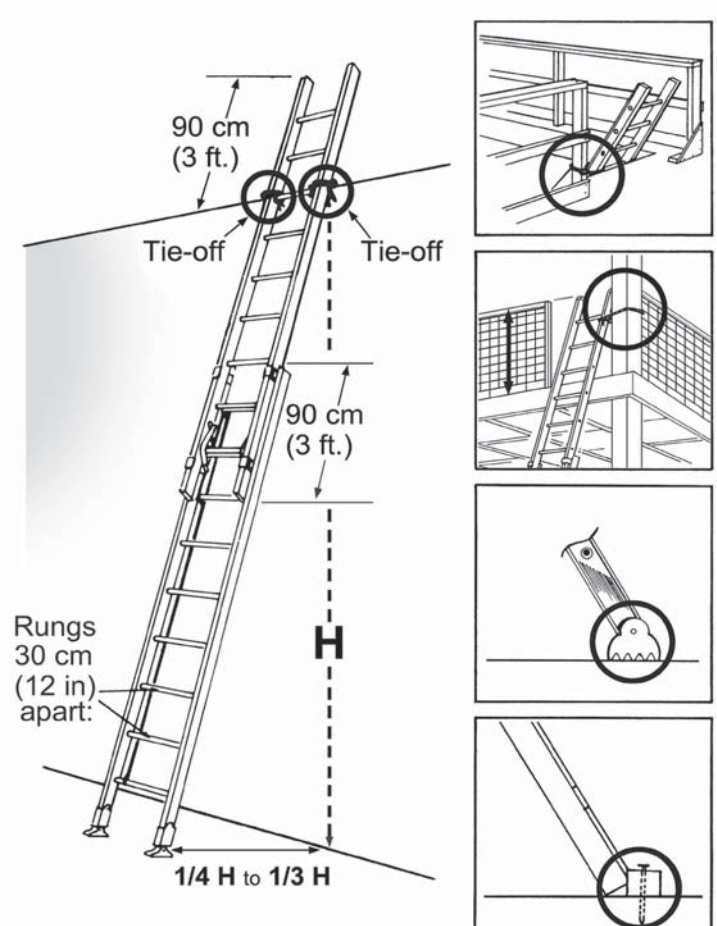

Proper way of securing a ladder

- be kept free of material, garbage, and debris at the top and bottom and be cleared of ice, snow, and other slippery substances
- be equipped, in the case of vertical ladders, with a cage or ladder climbing device and with rest platforms no more than 9 m (30 ft.) apart
- not to be used as work platforms

Do not carry materials and equipment up or down access ladders. Tools should be carried in a tool pouch or be hoisted by rope. Maintain three-point contact (two hands and one foot or two feet and one hand) at all times.

If there are no guardrails where the ladder reaches the roof, a barrier should be set up. The barrier will warn workers that the edge is close by.

Note: It is not advisable to use permanent exterior fixed ladders as a means of access to the roof. Many of these ladders have not been maintained or inspected since being installed, and may be in poor condition.

CHAPTER 15—Material Loading

Hoisting and Rigging

To roofers, rigging means overhead lifting. For safe rigging, you must

- know the weight of the load to be lifted
- know the capacity of the hoisting device
- know the safe working loads of the ropes and hardware
- never hoist over other workers or the general public.

A rigging or hoisting location should be clear of public entrances and access ways, emergency exits, fire escapes, and powerlines.

In addition, when hoisting, try to avoid parts of the building that can be easily damaged, such as windows, cladding or siding, and light fixtures. If that is not possible, provide protection.

Loading and unloading areas on the roof should be protected by a guardrail. If guardrails have been removed to hoist material and you are working less than 2 m from the edge, use a fall protection system that includes a full-body harness, preferably a travel-restraint system.

Before using the hoisting equipment, inspect it for defects and damage. Make sure the weight of the load does not go beyond the capacity of the hoist. Also, make sure the lading areas can support the additional load of roofing material.

Land materials at least 2 m from the edge of the roof or from openings. That keeps workers from having to approach the edge. It also helps to prevent materials from falling over and rolling off the edge.

Cranes

Before hoisting operations begin, a crane must be set up for lifting, and certain conditions must be met.

Know and follow safe rigging procedures. For more information, see IHSA's *Hoisting and Rigging Safety Manual* (M035).

Use international hoisting hand signals (see page 15-2) or two-way electronic communication.

Employers must make sure the signaller has received adequate training. Before hoisting, the signaller and the operator must agree on the procedures they intend to follow during the lift.

Make sure that the crane can reach the drop-off point and the pick-up point and that the load is properly secured. The drop-off point on the roof should be as close to the installation or storage point as possible and must be at least 2 m from the roof edge or any roof opening.

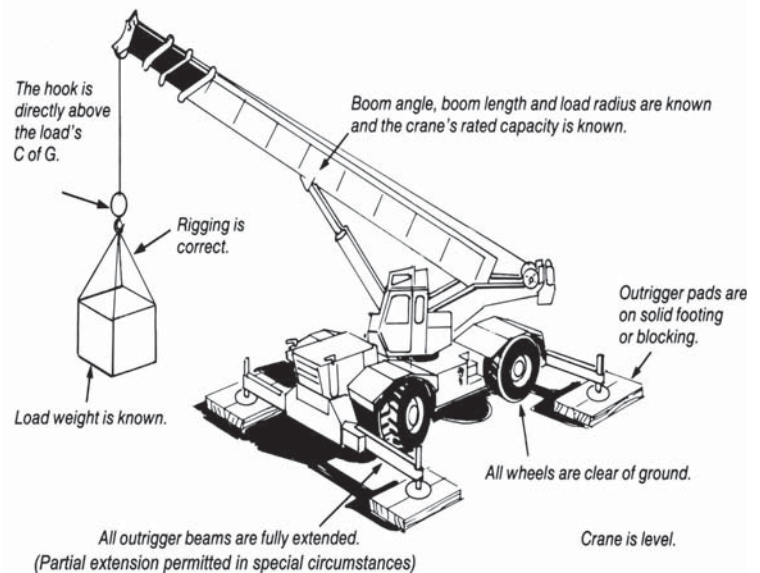

Correct crane set-up

Elevators

When a high-rise building is being roofed, hoisting equipment often needs to be transported on the elevator. When work has begun, workers often use the elevator for getting up onto the roof or getting down to ground level.

- Do not load the elevator beyond its lifting capacity.
- Protect the elevator from damage and from bitumen, solvents, and rough or sharp objects.

Motorized Hoists

There are three types of motorized hoist:

- ladder hoist
- conventional hoist
- hydraulic hoist.

HOISTING Hand Signals

<p>Load Up</p> <p>1</p>	<p>Load Down</p> <p>2</p>	<p>Load Up Slowly</p> <p>3</p>	<p>Load Down Slowly</p> <p>4</p>	<p>Boom Up</p> <p>5</p>	<p>Boom Down</p> <p>6</p>
<p>Boom Up Slowly</p> <p>7</p>	<p>Boom Down Slowly</p> <p>8</p>	<p>Boom Up Load Down</p> <p>9</p>	<p>Boom Down Load Up</p> <p>10</p>	<p>Everything Slowly</p> <p>11</p>	<p>Use Whip Line</p> <p>12</p>
<p>Use Main Line</p> <p>13</p>	<p>Travel Forward</p> <p>14</p>	<p>Turn Right</p> <p>15</p>	<p>Turn Left</p> <p>16</p>	<p>Shorten Hydraulic Boom</p> <p>17</p>	<p>Extend Hydraulic Boom</p> <p>18</p>
<p>Swing Load</p> <p>19</p>	<p>Stop</p> <p>20</p>	<p>Close Clam</p> <p>21</p>	<p>Open Clam</p> <p>22</p>	<p>Dog Everything</p> <p>23</p>	<p>NO RESPONSE SHOULD BE MADE TO UNCLEAR SIGNALS</p> <p>24</p>

Ladder Hoists

When setting up a ladder hoist, follow the ladder principle. The slope should be 3:1 or 4:1. That's one foot out for every 3 or 4 ft up. The top and bottom of the ladder must be secured.

Refer to the ladder section in Chapter 13 for additional considerations.

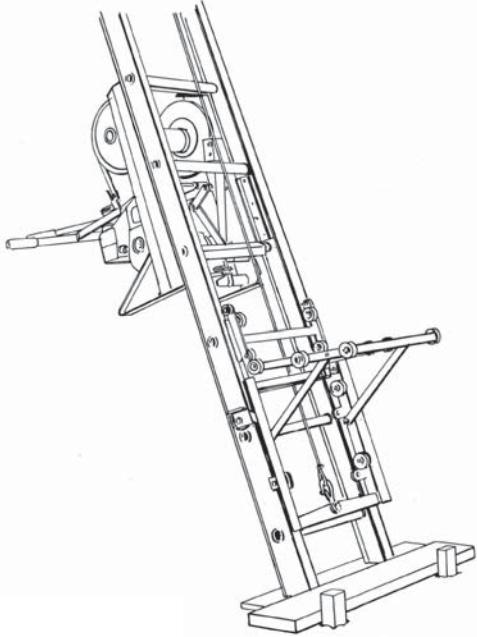

Ladder hoist

Caution: Never use a hoist to transport people.

Conventional and Hydraulic Hoists

The conventional powered hoist is the most popular in Ontario because it is inexpensive. However, it has the drawback of using the two-lever clutch and brake system. This makes it more difficult to operate than a hydraulic unit, which is operated with a switch.

When roofing hoists are located at the edge of the roof, there must be guardrails that extend at least 90 cm (3 ft) on both sides of the frame and that are set up in accordance with the manufacturer's instructions. Wherever possible, a roofing hoist should be set up at least 3 m (10 ft) from an outside corner.

Where the hoist must be set up closer to a corner, an additional guardrail must be attached to the guardrail on the hoist and a warning line set up to protect workers from the second edge.

A hoist must be erected so that the cable remains vertical at all times while a load is being hoisted. In addition, the hoist arrangement must have a safety factor of not less than three against overturning.

When workers are in the hoisting area, they must be protected from fall hazards with guardrails or a secondary means such as a fall protection system.



Typical roof hoist system

When preparing to use a hoist, take the following precautions:

- Make sure the hoist is inspected and is fit for safe use before it is delivered to the jobsite.
- Do not overload the roof with counterweights and roofing material.
- Assemble the frame and hoist away from the edge of the roof. Move it to the edge once the assembly is complete.
- Protect the roof when assembling, dismantling, and operating the hoist.
- Secure all counterweights to the frame.
- Use the counterweights suggested by the manufacturer, with the weight marked. Do not use roofing material.
- Inspect the hoist every day. Look for things like loose bolts or pins, cracked or frayed cable, bad welds, and other defects.
- Keep the hoist's instruction manual at the jobsite.

The operator of the hoist must

- be competent to operate, assemble, and dismantle the hoist
- never exceed the load rating capacity

- make sure the load is always secure and all workers are clear of the hoisting area
- be sure the hoist is never adjusted or repaired when it is running
- use a tag line when there is a danger the load may swing or drift out of control
- make sure the hoisting area is barricaded from the public
- make sure that communication is clear and reliable. Use hand signals or two-way electronic communications when necessary.

Caution: Use a sling to tie a choke hitch on material. Do not loop the hoisting cable around the hook.

Gin Wheels (Hand Hoists)

A gin wheel is an ideal hoisting device in low-rise buildings (three floors or less). For buildings taller than three floors, if possible, use a gin wheel only to transport the counterweights and the hoisting frames for larger projects or materials for smaller jobs such as repairs.

Asphalt Pipes and Discharge Area

Where hot asphalt is pumped to the roof and discharged into a container or similar device within 2 m (6 ft 6 in) of the roof edge, a guardrail or barrier should be installed at the roof edge. In addition, the pipe supplying the asphalt should be adequately supported and fixed in position so that it cannot present a hazard to workers on the roof if it moves or bends.



Asphalt pipe at roof level

A hot-asphalt container or similar device supplied by the discharge pipe must be fixed or blocked in position and the pipe fastened securely to it.

The discharge area is dangerous. Limit access to it with barricades, and keep the area clear of all material, tools, and debris.

Conveyers

A conveyer is another means of moving ballast from the ground to the roof. The ballast is generally loaded into the hopper with a loader or skid steer. Because of the danger from moving equipment, access to the area should be restricted.

Conveyers are designed to move gravel only.

Equipment and personnel must never be moved on a conveyer.

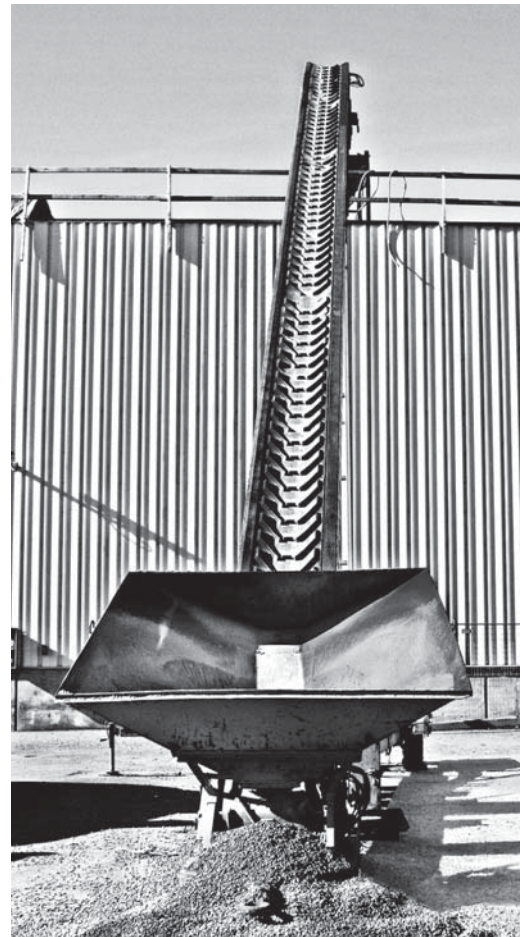

Material conveyor

CHAPTER 16—Kettles and Tankers

Kettle Start-Up

- Set kettles on smooth, level ground to create an even distribution of asphalt in the kettle and prevent pumping problems. The area must be clear of flammable debris or materials, well ventilated, and as close as possible to the place where the asphalt will be applied.
- Make sure that the rear leveller leg is in a secure down position.
- Make sure the kettle is level and most of the weight is taken by the legs rather than the tires.
- A fully charged fire extinguisher of at least 4A4OBC rating should always be available near—but not on—the kettle.
- Whenever possible, protect kettles from the wind.
- Before lighting the burner, check the kettle vat for moisture. Moisture in hot asphalt will cause foaming and bubbling. This can cause the scalding asphalt to overflow or splatter. Make sure you know the flash point and working temperature. These temperatures should never be exceeded.
- Check to make sure discharge pipes are clear and free of solid asphalt before pumping



Kettleman at work

- Make sure the kettle and pump are in good working condition and the pump is strong enough.

- Check equipment pump lines and fittings for defects and incorrect installation.
- Make sure the pump line valve is working properly.
- Guards must be placed so as to enclose pump gears and sprockets.
- Before firing, check the hoses, gauges, fuel tanks, burners, and other equipment for defects and leaks and make sure the kettle lid fits tightly.
- Propane gas cylinders must be secured in an upright position at least 3 m (10 ft) from the kettle burner.
- Never light the burner while it is in the burner well. If there is too much propane in the well, there may be a flashback. Use the size of burner specified by the manufacturer. Never use oversized burners. They may cause the tubes to become overheated, resulting in a fire or explosion.
- Light the burner outside, and then place it in the heating tube. Remember that flames are hard to see on a bright day. Burners should never be fired at full thrust until there's at least 15 cm (6 in) of melt covering the heating tubes.
- Check the temperature periodically with a hand-held thermometer. Also check the melt temperature. A thermometer can be used to calibrate kettle gauges.

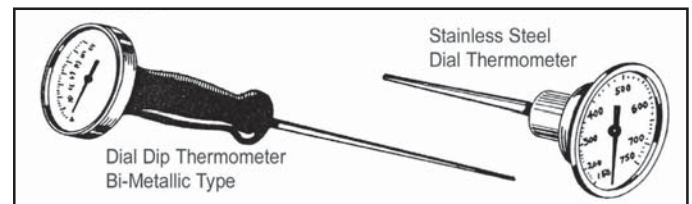

Thermometers

Warning: Many kettle temperature gauges do not work properly.

- Put the burner in a safe spot when it is removed from the kettle.
- Always turn off the burner and engine before refuelling. Sparks from a running motor can ignite the fuel vapours.
- At night, secure the burners, lid, draw-off cock, and fuel.
- Support and secure the pipeline to prevent kinking and unwanted movement.

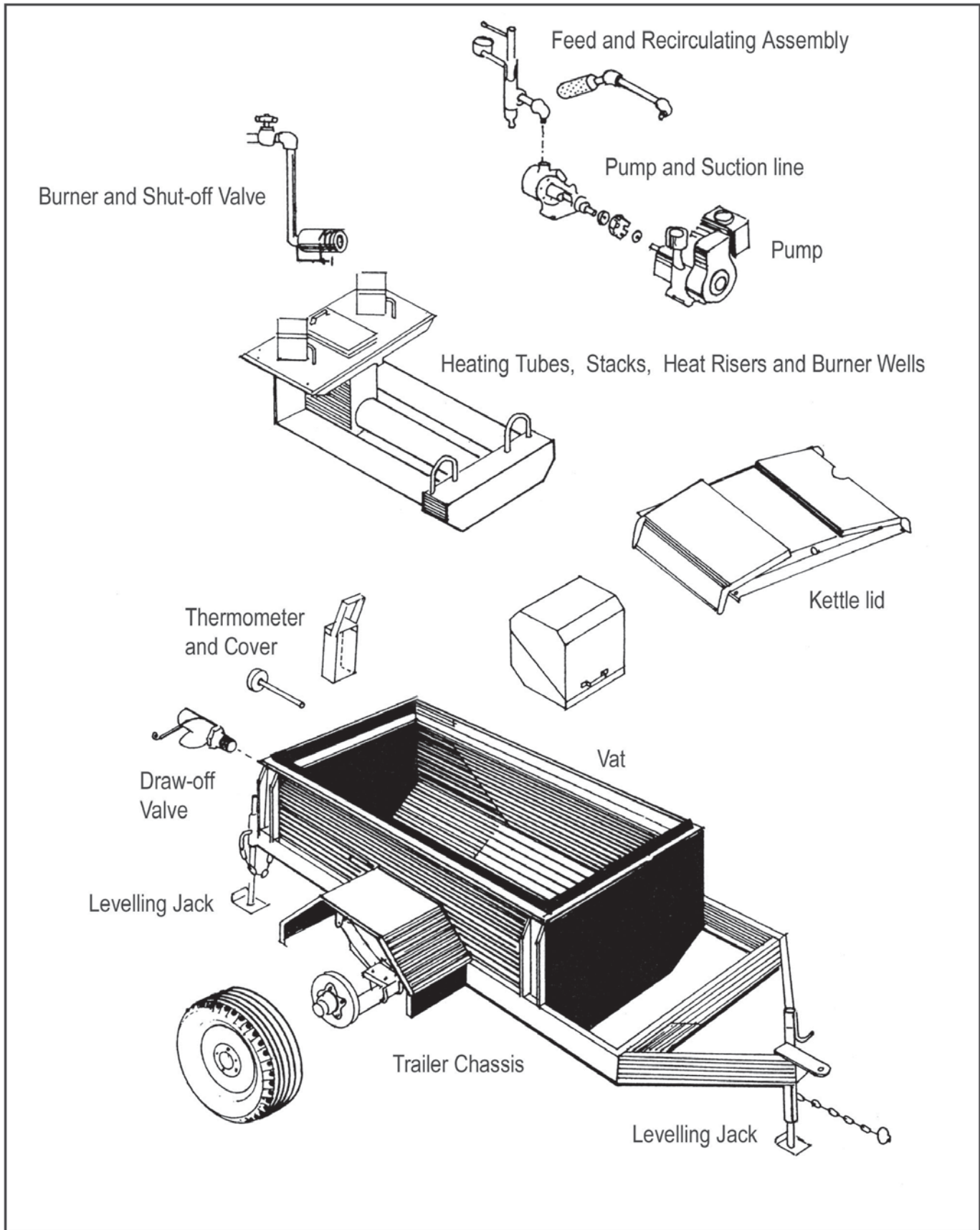

Typical kettle components

Loading of Kettles

- Adding cold asphalt to the kettle can be a dangerous operation. Wear the proper protective clothing, a CSA-certified face shield, protective glasses, long sleeves, and oversized roofers gloves.
- Cut cold asphalt into small chunks so that it won't cause the hot asphalt to splash when it's put into the kettle.
- The kettle should never be filled up. Asphalt expands when it's heated, and it may overflow. Heat cold material slowly.
- The burners should not be fired at full thrust until the heating tubes are covered with at least 15 cm (6 in) of melt. Firing the burners at full thrust will damage the tubes and crack the burner.
- Try not to stir the hot asphalt by hand. If it must be stirred by hand, use a long, solid piece of wood. Never use a hollow pipe because moisture in the pipe can cause the hot material to flow up through the pipe and burn you.
- The material should not be heated above 260°C (500°F).
- Keep the inside and outside of the kettle clean and free of debris and flammable material. A buildup of asphalt can create a fire that is very difficult to extinguish.

Kettle Fires

If there is a kettle fire:

1. Turn off the fuel supply at the tank and close the kettle lid.
2. Call for help.

Remember, a fully charged 4A4OBC fire extinguisher must always be nearby.

Shutdown of Kettles

When shutting down a kettle, follow these steps:

1. Turn the fuel off.
2. Turn the burners off and remove them.
3. Close the lids and lock them.
4. Lock the drain cock.
5. Lock the pump cowling.
6. Secure the area.

Note: Before leaving a kettle at the end of the day, the kettleman must make sure each of those things has been done.

Always refer to the manufacturer's instructions for specific shutdown procedures.

Rooftop Kettles

It is not advisable to operate a kettle on a rooftop. However, when that is the only option, extra precautions must be taken.

- Have at least twice the required number of fire extinguishers on hand.
- Make sure that someone is tending the kettle at all times.
- Set the kettle on a non-combustible surface.
- Locate the kettles away from walls and access ways.
- Do not allow the asphalt to overheat.
- Put up barriers to restrict access to the kettle area.
- Have an emergency plan.

Emission Control System on Kettles (Smokeless Kettles)

Dipsticks

It is important to monitor the asphalt level.

There must always be at least 6 inches of asphalt above the tubes.

Kettles with emission-control systems come with dipsticks for installation on the kettle. The dipstick must be checked constantly for an accurate measurement of the asphalt level inside the kettle.

Safety Loaders

Always use the safety loader to load chopped asphalt into the kettle.

Note: It takes longer to load the kettle through a safety loader. That's because only small pieces of asphalt can be used so that they don't stack up under the loader and block it.

After loading the chopped asphalt into the loader, shut the lid and make sure the lid lock catches.

Use the roll bar to dump the chopped asphalt into the kettle. Make sure the roll bar returns to the closed position. If it is blocked and doesn't go back to the closed position, the operator could be exposed to asphalt smoke the next time the lid is opened.



Safety loader

- The double screens provide protection against flames in the event of a blowback. They also prevent asphalt from splashing up into the burner area.
- Never start the emission control system without the fire arrester screens in place. If you do, there could be a kettle flash and serious injuries.
- Clean the screens at the beginning of every work day.
- If there are any cuts or holes, the fire screens must be replaced.
- Follow all the manufacturer's instructions.

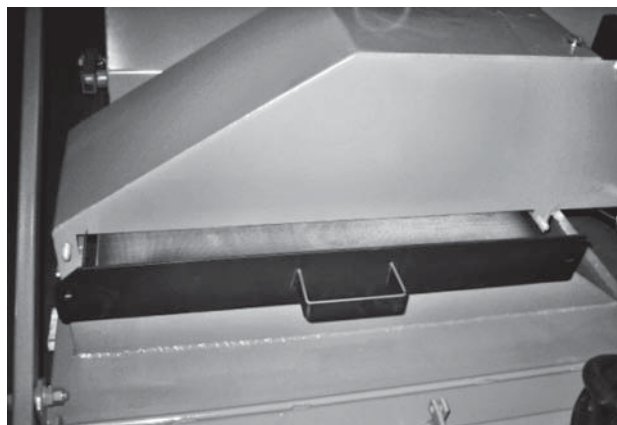

Fire arrester screens (filters)

- The afterburner should always be running when the emission lid is installed on the kettle. Watch continually to make sure the burner is lit, because the wind can blow the flame out.
- Never touch the burner stack on the emission control system. It is very hot and will cause burns.
- The propane tank must be at least 3 m (10 ft) from any source of ignition. Large propane tanks must be 25 ft away. When you're shutting down for the day, turn off the cylinder valve first and let the existing gas burn out. Then shut off all the other valves.

Warming the Kettle

Warm the flue before bringing the flame up to operating pressure.

Warning: In winter, the asphalt can become solid and create a seal around the openings of the kettle. If that happens, the pressure in the kettle can build up.

Tankers

The driver is responsible for the safe operation of the tanker and for safe practices around the tanker and kettle.

Setup

Asphalt tankers should be positioned as level as possible and on firm ground. When a tanker is set up on a slope or is badly out of level, the heating tubes become exposed at the high end of the tank as asphalt is drawn off. The exposed tubes overheat and create a dangerous situation that could easily result in a fire or explosion.



Setting up tanker on slopes creates ideal conditions for fires

To ensure that the tanker will be stable enough, support each of the trailer dollies on a pad resting on firm ground and provide extra support in the form of wood cribbing or jacks at the front of the trailer.

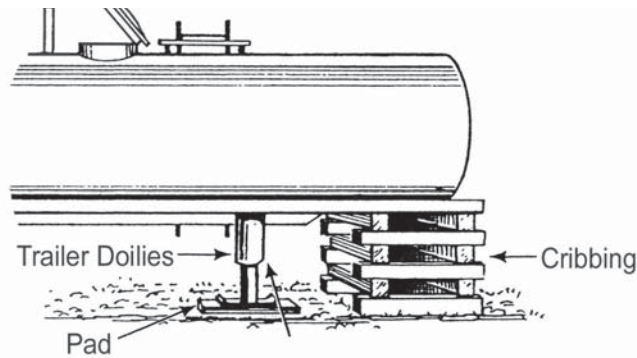

Tanker cribbing

Operation

- Before firing the burner, open the exhaust stack covers. Close them when the burner is shut down to reduce heat loss.
 - Never fire the burners unless the heating tubes are covered with material. Do not draw off material below the tops of the tubes while burners are ignited.
 - If the draw-off valves are below the level of the heating tubes, be extremely careful to keep material above the level of the heating tubes while the burners are operating.
 - When asphalt is being heated, the tank access cover should be slightly open to allow volatile gases to escape and the pressure to equalize. In the event of an explosion, the cover will act as a relief port.
 - When heating cold material, regardless of the material level, lower the fuel pressure and bring the temperature up slowly until the pump is free. Then raise the pressure to normal.
 - Do not operate burners at more than 138 kilopascals (20 psi).
 - Do not exceed the manufacturer's recommended maximum temperature for materials. Temperatures above this level can ignite the vapours in the tank and cause a fire or explosion.
 - Do not stand over the tanker access when filling an already heated empty tank. The vent pipe emits the volatile flammable vapours given off when asphalt is heated.
 - The vent pipe must be open. If it becomes plugged, flammable vapours can build up to explosive levels inside the tank.
- Do not use an open flame on top of the tank at any time because it could ignite the fumes from the tank.
 - If a vent pipe freezes, remove all piping and take it to a place far from the tanker for thawing.
 - A common method for checking the asphalt level is to lower a measuring rod through the access. Use a solid rod rather than an open pipe, which will let hot asphalt splash up through its hollow core.

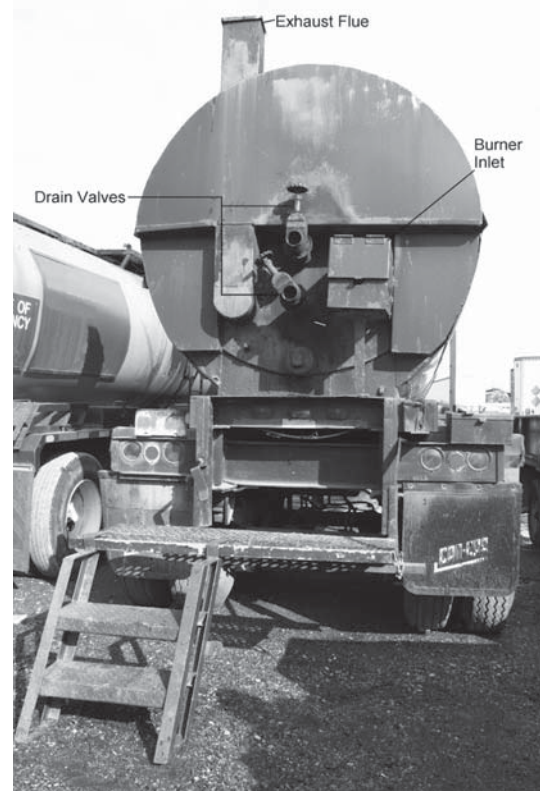

Tanker with proper access

- Do not light a burner when it is near any flammable material.
- Turn off the burners and engines before refuelling. Let the burners cool.
- At night, secure the burner, the access cover, the kettle lid, the draw-off cock, and the fuel.
- When transferring asphalt from the tanker to the kettle, use a pipe, not a chute or trough.
- Always keep a fully charged 4A40BC fire extinguisher handy.
- Follow all the tank manufacturer's operating and maintenance instructions.

Note: Kettle operators must monitor the kettles at all times when they are in operation.

CHAPTER 17—Propane, Burners, and Torches

Propane tanks or cylinders are available in different sizes with different methods of fuel withdrawal (liquid or vapour). The liquid gas at the bottom of the tank must never come in contact with the relief valve. When transporting, using, or storing cylinders, the cylinder relief valve must remain in contact with the vapour space.

NOTE: Never connect a vapour-withdrawal propane cylinder to a liquid-propane appliance and vice-versa.

Training

All workers must be trained before handling or using propane on a jobsite.

- You must have a record of training (ROT) recognized by the Technical Standards and Safety Authority (TSSA) before you can off-load, hook up, or light a propane-fired heater.
- This training must be updated every three years. IHSA offers a *Propane in Roofing* course.

General Propane Safety

A propane burner system consists of a fuel container designed for a specific type of withdrawal (liquid or vapour), a main container valve and collar cap, a pressure regulator, a pressure gauge, a burner shut-off valve, a fuel line or approved hose, and a burner assembly.

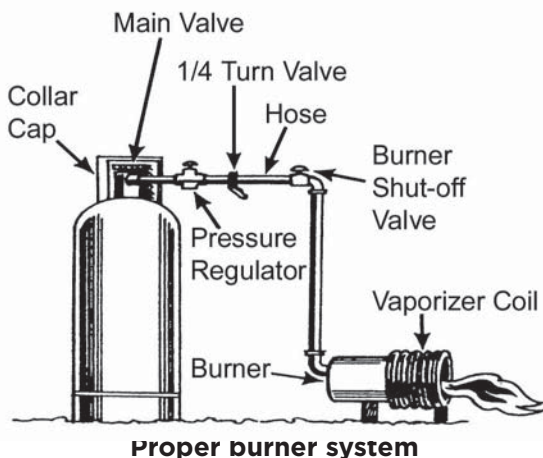

Note: The burner should always be kept at least 3 m (10 ft) away from the tank.

Containers for liquid withdrawal are equipped with a dip tube. Containers for vapour withdrawal have no dip tube, and only vaporous gas can be withdrawn.

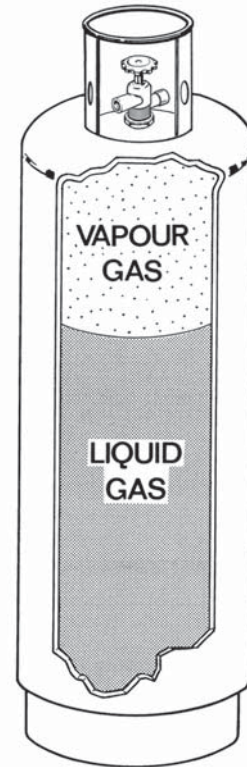

Cutaway view of vapour-withdrawal propane cylinder

Precautions with Propane Equipment

- Make sure the hoses are in good condition and all connections have been tightened and soap tested by a qualified worker holding a propane certificate.
- Handle propane cylinders with care. When they are not being used, store empty and full cylinders in a designated location that is shaded, not close to flammable materials, and protected against damage and vandalism. Container valves must be closed tightly. Protective collars or caps must be in place.
- Unless specifically designed for horizontal use, all cylinders must be transported, used, and stored in an upright position. The safety relief valve must be open to the vapour space above the liquid gas.



Propane tank, upright and secured on a cart

- A cylinder inside a building must not be located near an exit, a stairway, or a place normally used or intended for evacuating the building.
- Cylinders must be connected and disconnected in a well-ventilated area. There must be no source of ignition within 3 m (10 ft) of the connection point.
- Never put propane containers—full or empty—below ground level unless it is absolutely necessary.
- Remember that propane is heavier than air. If there is a leak, it will seek the lowest possible level and collect in places such as trenches, excavations, and basements.
- Never heat a propane container.
- Never hoist a propane cylinder by its collar—use a hoisting carriage.

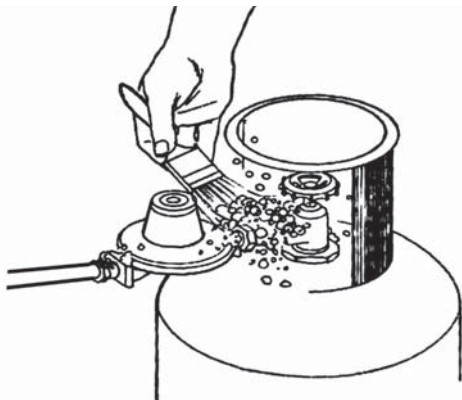

Detection of leaks

- A propane burner system must be tested for leaks before being used. To detect the source of a leak, brush soapy water over the joint. If there is a leak, the gas supply must be turned off immediately at the container. Never use a flame to test for leaks.

Precautions with Propane Burners

- When a burner is lit, it must be at least 3 m (10 ft) away from any 45.4-kg (100-lb) propane cylinder and at least 7.6 m (25 ft) away from any larger propane tank.

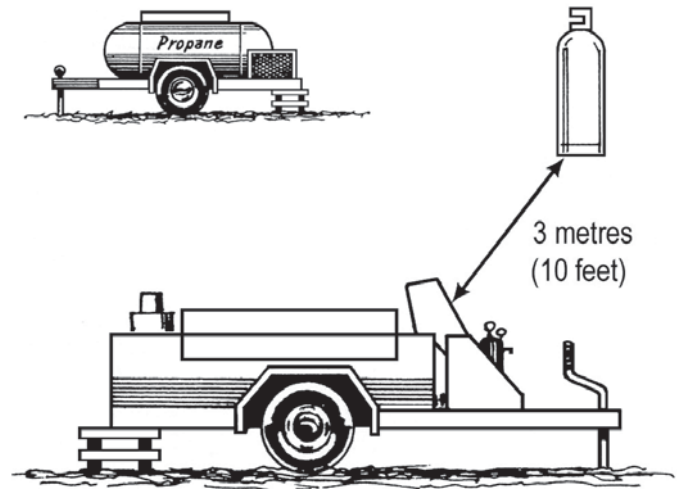

Burner at safe distance from cylinders and large tank

- To light a burner, use only a flint sparker or igniter.
- Once a burner has been lit, never direct it towards any person or flammable object. There is a dangerous invisible extension of the flame that can cause a fire, considerable damage, and serious burns if a burner is handled carelessly.
- Once a burner has been lit, never leave it unattended.
- Never use an open flame to detect leaks in the propane system. This can cause serious fires and even explosions.
- To prevent the excess flow valve from closing too soon, open the container valve slowly until it is fully open. If an excess flow valve closes during normal operation, close the container valve immediately. Do not use the container until the supplier is notified and the problem is corrected.
- Equipment must be maintained and repaired only by specially trained persons.

Precautions with Hand-Held Torches

Hand-held torches are used for many operations in the roofing industry, such as melting snow and ice, drying roof decks, and heat sealing.



Worker with hand-held torch

- When you are using a hand-held torch inside a building, be sure there is proper ventilation.
- Never leave an ignited hand torch unattended.
- When an operation is finished, always shut off the container valve first. Allow the gas in the system to burn off. After the flame has gone out, shut off the torch control.
- Make sure the propane cylinder is properly secured and in an upright position.
- Be sure to use an approved high-pressure hose to connect the torch to the pressure regulator.
- Operate the torch at the manufacturer's recommended pressure.
- Never direct the flame from the torch onto or towards a propane cylinder.

Safety Checklist

- Before lighting any burner, have at least one fire extinguisher or the number required by the construction regulations.
- Equipment containing burners must never be towed or transported while a burner is in operation.
- Propane cylinders must always be stored, secured, and transported in an upright position and with the cylinder valve closed.
- Protective collars must be on cylinders at all times.
- A cylinder being used inside a building must not be located near an exit, stairway, or area normally used or intended for evacuating the building.
- Cylinders must be connected and disconnected in a well-ventilated place with no source of ignition within 3 m (10 ft) of the connection point.
- When a cylinder is not being used, the pressure regulator must be removed.
- Never force brass or bronze fittings to avoid stripping the thread.
- Always check hose and connections for damage and leaks before using equipment.
- Use a proper leak-check solution to check all joints for leaks. Never use a flame to check for leaks.
- All valves must be fully open when the system is in operation. The only thing regulating the flow of gas should be the pressure regulator.
- All valves must be closed when the burner is not in use.
- When an operation is finished, always shut off the container valve first. Allow the gas in the system to burn off. After the flame has gone out, shut off the torch control.
- Relief valves on cylinders must always point away from the burner.
- Never use a burner bigger than recommended for the piece of equipment. If you do, it will burn out the heating tubes, damage the quality of the asphalt, or cause a fire or explosion.
- Never light a burner while it is in the kettle or tanker.
- Never put a hose into the burner well of a kettle.

CHAPTER 18—Night Roofing

Roofing work that is done at night is dangerous and is not recommended. However, it is popular with owners of non-residential buildings because it does not disrupt the building operations during regular business hours and people using the building are not bothered by noise or the smell of asphalt.

The main reasons that night roofing is dangerous are the following:

- poor visibility at night
- electrical hazards from artificial lights
- lack of alertness in night workers
- potential at certain times of the year for dew or frost, which can cause single-ply membranes to become dangerously slippery.

Poor Visibility

Roofing entails working at heights with molten asphalt and open flames, handling heavy materials, operating power equipment, and other high-risk activities. These hazards are compounded when working at night with poor visibility.

Fall Prevention

At night, the risk of falls and injury, which are always present in roofing work, are much greater because of the darkness.

- Set up barricades around work areas to prevent workers from leaving the illuminated work area.
- Install guardrails wherever there is a risk of falling through openings and skylights.
- Erect guardrails, with their own lighting, to form runways between entrances, exits, and work areas.
- Entrances, exits, ladders, stairs, and hoist locations all require their own lighting.
- Attach reflective tape to all guardrails, roof edges, and perimeters to help the workers recognize possible hazards and unsafe places.
- It is advisable to have workers wear reflective clothing.

Housekeeping

With the lack of daylight, good housekeeping during night roofing is of the utmost importance.

- Make sure to have a proper site plan, and train workers on that plan.
- Pay special attention to keeping access ways, building edges, and roof openings clear.

For more information, see Chapter 6—“Planning and Housekeeping” (p. 6 - 1).

Artificial Light

If work is to be done in the dark, it is essential to have adequate artificial lighting.

- Make sure there is enough light for workers to move around safely in the work area.
- Make sure the lights don't cast long shadows that hide the hazards from view.
- Make sure the lights don't cause temporary blindness by shining into the workers' eyes.

Warning: No amount of temporary lighting can duplicate daylight conditions.

Electrical Hazards

- Temporary lighting must follow basic electrical safety principles.
 - Water and moisture, which are common in outdoor work, can create a serious electrical hazard and subject workers to electrical shock.
 - The equipment must be robust enough to withstand rough handling.
 - As roofing often involves the use of flammable materials and volatile fuels, the lighting equipment should be explosion-proof to prevent sparking or ignition of these materials.
- Use lights that are portable and lightweight, so they can be moved easily to where the work is being done.

- Make sure the cables supplying power do not pose a hazard from tripping or electric shock.
- Have backup lighting and generators on hand in case any of the equipment breaks down.

Alertness of Workers

Workers and employers should all be aware that workers who put in long hours at night tend to be less alert than those who work during the day. Therefore they are more prone to accidents.

There are two reasons for their lack of alertness:

- (1) a person's "body clock" can be disturbed by shift or night work
- (2) night workers may not be getting enough sleep.

CHAPTER 19—Vehicle Safety and the Transportation of Dangerous Goods

Vehicles

Before each shift, do a basic vehicle inspection. The following “daily circle check” is a good procedure:

- Parking brake—adequate to hold vehicle.
- Fluid levels—oil, gas, and brakes. Check for leaks.
- Lights and turn signals—functioning.
- Visibility—mirrors properly adjusted, windows clean and intact.
- Wiper and washer—functioning.
- Tires—pressure, depth of tread, damage.
- Wheels and fasteners—defects in rim, loose or missing fasteners.
- Emergency equipment—install and inspect as required by law or company policy.
- Fire extinguisher—vehicle equipped with a fully charged dry-chemical fire extinguisher (4A40BC).
- First aid kit—fully stocked
- Load—secure and evenly distributed.
- Driver’s line of sight and mirror—not obstructed by material or equipment.
- Everything securely in place. (Hard hats and other equipment can become flying objects in an accident.)

Note: Vehicle safety is governed by the federal *Highway Traffic Act*, Reg. 199/07 and Reg. 611.

Note: Record any defects, and report them to your supervisor immediately.

DAILY CIRCLE CHECK

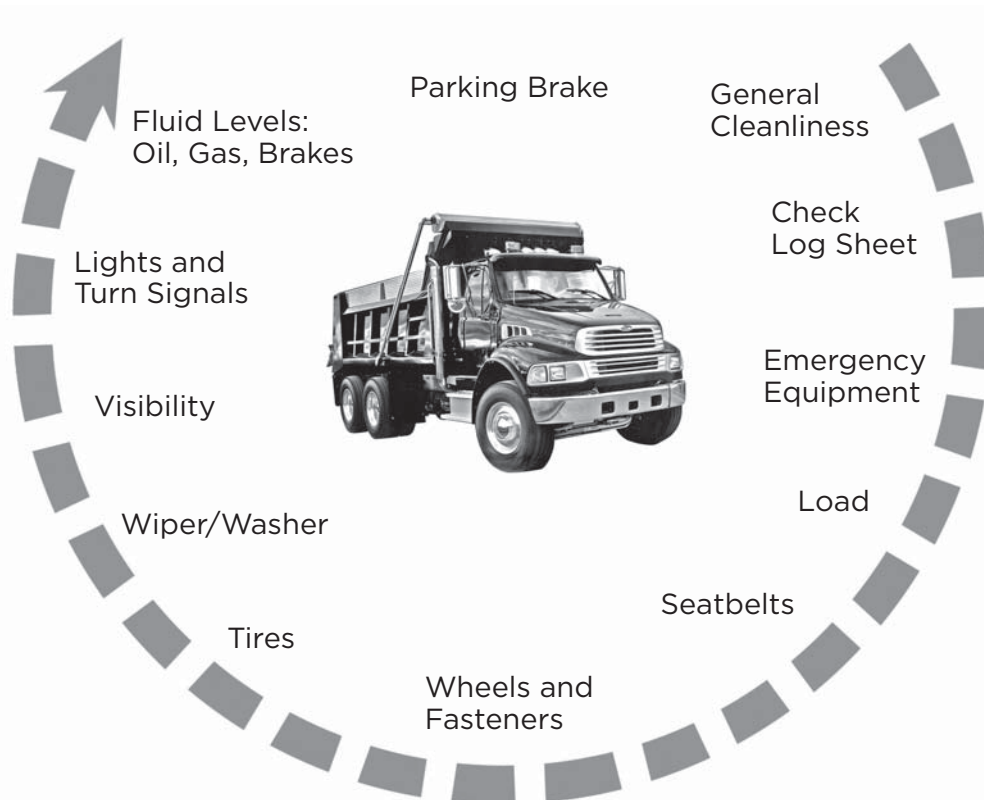

Trailers

Note: Trailer safety is governed by the federal *Highway Traffic Act*, Reg. 199/07 and Reg. 611.

Before using a trailer, be sure it is in safe operating condition. Inspect the following:

- lights
 - tires
 - brakes
 - bearings
 - safety chains
 - hitch.
- Use the right class of trailer hitch on your vehicle:
 - Class I—up to 2,000 lb
 - Class II—up to 3,500 lb
 - Class III—up to 5,000 lb
 - Class IV—up to 10,000 lb
 - A trailer requires two separate means of attachment to the vehicle. A typical arrangement incorporates a ball hitch with two safety chains. The capacity of each chain should be equal to the gross weight of the trailer and should cross under the tongue to connect to the hitch.
 - Loose objects must be covered with a tarp. All loads on trucks and trailers must be secured or placed so that no part of the load can become dislodged or fall off the vehicle.
 - Anchor points, rope, and slings used for tie-downs must be in good condition. Inspect them before each use.
 - Check the *Highway Traffic Act*, Ontario Reg. 199/07, for pre-trip and annual safety-evaluation requirements when using trailers.

Transportation of Dangerous Goods

The *Transportation of Dangerous Goods Act* (TDG Act) applies to roofing contractors whenever they are transporting hazardous material on a road or highway. It is the obligation of roofing contractors to understand the requirements of this Act.

Under the TDG Act, the driver and owner of the vehicle also have responsibilities and obligations. For more information, contact IHSA, which provides training, or a local Ministry of Transportation office.

If you are transporting more than 150 kg (300 lb) of dangerous goods, you must be specially trained (TDG Act).

Read the material safety data sheet (MSDS) of each material you are transporting. It may contain specific information about transporting that material.

Note: A driver who is transporting propane must also follow the Propane Storage and Handling Code (in Ont. Reg. 223/01 under the *Technical Standards and Handling Act*).

APPENDIX—Musculoskeletal Disorders

Musculoskeletal Hazards and Controls Roofers

Musculoskeletal disorders (MSDs), such as chronic back pain or shoulder problems, often take time to develop. Forceful exertion, awkward positions, hand-arm and whole-body vibration, contact stress, and repetitive tasks can add up over time to produce an MSD.

This profile can help you identify and control MSD hazards in your job. We recommend that you add the best practices outlined here to your company's health and safety program. The hazards in a particular job, however, may be different than the ones on this profile, so evaluate the risks of your particular activities.

In general, when implementing controls, consider the following ergonomic principles:

- 1. Use handling equipment when possible.** The most effective intervention to control the risk of developing an MSD is to eliminate or reduce the frequency of lifting, carrying, pushing, and pulling. Use material-handling equipment such as carts, dollies, pallet jacks, or manual forklifts.
- 2. Don't lift a load from the floor.** Lifting from the floor or below standing knuckle height can expose your back to significant stresses and reduce your lifting capacity. Avoid this procedure by storing objects above standing knuckle height and below standing shoulder height.
- 3. Avoid working on the floor.** Constantly working on the floor can result in injuries to your back, hips, and knees because it usually requires kneeling and bending your back forward. When possible, raise the work height by using a workbench.
- 4. Minimize work above your shoulder.** High lifting or constant reaching above the shoulder level is harmful for three reasons.
 1. Your muscle strength is reduced because most of the muscle work is performed by your shoulders and arms instead of by the bigger muscles in your back and legs.
 2. Your shoulder and arm muscles fatigue more quickly than your back and leg muscles because of reduced blood flow.
 3. Lifting or removing an object from a high shelf can be dangerous because you could drop the object.
- 5. Move smaller weights often or get help.** Smaller weights put less stress on your back than larger weights, even if the frequency of lifting is increased.
- 6. Exercise programs.** Consider exercise programs. They help to prevent MSDs and promote general good health.

Note: The hazards and controls described in the following chart are examples and do not cover all possible situations.

Tasks	What can happen (Hazards/Risks)	Potential Controls
<p>Strips and removes roofing materials from roof cavity</p>	<ul style="list-style-type: none"> ▶ Lower back and shoulder injuries ▶ Overexertion injuries while manually handling old roofing materials and removing old battens or roof frames 	<ul style="list-style-type: none"> ▶ Use upright scraping tools whenever possible. These tools give you mechanical leverage and reduce the need to bend forward. ▶ Use mechanical dollies, wheelbarrows/carts, or buggies to carry roofing materials when possible. ▶ Use mechanical lifting, cutting, and removal equipment when possible. ▶ Use shovels to lift small items into a wheelbarrow or cart.
<p>Applies built-up roofing components</p> <ul style="list-style-type: none"> ▶ Applies vapour barriers and air barriers ▶ Installs insulation ▶ Installs protection board ▶ Installs drains, vents, and roof fixtures ▶ Applies ballast and protective surfaces ▶ Fits roof accessories, (e.g., barge and ridge caps) 	<ul style="list-style-type: none"> ▶ Repetitive forward bending while using a screw gun or nail gun to secure battens, vapour barrier, protection board, and insulation ▶ Knee and back injuries due to squatting and kneeling while working on the roof (e.g., while cutting roof materials such as battens, insulation, protection board, or barriers) ▶ Overexertion due to manually placing materials onto the roof such as lifting roof sheets into position, moving vapour barriers, handling long metal roof battens, and lifting accessories into position ▶ Bending forward to install accessories 	<ul style="list-style-type: none"> ▶ Consider using upright automatic-feeding screw guns. This mechanical tool allows workers to stand upright instead of having to bend forward. ▶ Avoid working on the roof surface whenever possible. For example, cut roof materials on a mobile table. ▶ Use mechanical handling machines, such as powered buggies, when moving materials around the work area. ▶ Use mechanical equipment or get help from another worker if one piece of material is greater than what you can safely handle. Consider the weight of the item, the lifting location, and your posture. ▶ For roofing membranes greater than two metres, more than one person should lift long lengths of capping or other accessories. ▶ Use proper lifting techniques. Lift materials with your legs (do not bend over to lift with your back) and keep the load close to your body. See the chapter on “Back Care” in IHSA’s <i>Construction Health and Safety Manual (M029)</i>. ▶ Use mechanical devices to spread gravel when possible. ▶ Use powered mechanical caulking equipment when possible.

Tasks	What can happen (Hazards/Risks)	Potential Controls
		<ul style="list-style-type: none"> ▶ Arrange material to minimize the amount you have to twist and bend. ▶ Allow workers to choose between various mop sizes. ▶ Break up blocks into three or more pieces. ▶ Roll asphalt kegs instead of lifting them from a pallet. ▶ Purchase smaller asphalt blocks to reduce weight. ▶ Use an asphalt tanker truck instead of a kettle.
<p>Applies membranes</p> <ul style="list-style-type: none"> ▶ Applies membranes using hot process ▶ Applies membranes using torched-on method ▶ Applies membranes using hot-air welding ▶ Applies membranes using cold process ▶ Applies membranes using mechanical fasteners ▶ Applies loose-laid membranes ▶ Installs membrane flashings ▶ Installs liquid applied roofing membrane 	<ul style="list-style-type: none"> ▶ Manually handles propane and torches ▶ Lifts and carries roofing membranes 	<ul style="list-style-type: none"> ▶ Use mechanical equipment or get help from another worker if one piece of material is greater than what you can safely handle. Consider the weight of the item, the lifting location, and your posture. ▶ Use proper lifting techniques. Lift materials with your legs (do not bend over to lift with your back) and keep the load close to your body. See the chapter on “Back Care” in IHSA’s <i>Construction Health and Safety Manual</i> (M029).

About IHSA

IHSA's vision is workplaces without injuries, illnesses, or fatalities.

We engage with our member firms, workers, and other stakeholders to help them continuously improve their health and safety performance. We do this by providing effective and innovative sector-specific programs, products, and services.

We offer

- Training programs
- Consulting services
- Health and safety audits
- Publications and e-news
- Posters and stickers
- Reference material
- A resource-rich website
- Solutions to high-risk activities
- Due diligence solutions.

Find out what we can do for you at ihsa.ca

Infrastructure Health & Safety Association (IHSA)

5110 Creekbank Road, Suite 400
Mississauga, Ontario L4W 0A1 Canada
Tel: 1-800-263-5024 • Fax: 905-625-8998
ihsa.ca

